

# DIAGNOSIS OF THE ELECTRIC GENERATOR STATOR CORE BY MEANS OF THE LOW INDUCTION IRON TEST, PROFIM

Rodica ZLATANOVICI, Dan ZLATANOVICI  
ICEMENERG Bucharest  
danz@icemenerg.ro

**Abstract - Some of the electric generator stator core faults can be traditionally detected by means of the high induction iron test consisting in inducing a magnetic induction of about 1.0 -1.4 T to the core and measuring its temperature. The occurrence of a possible fault may determine a temperature increase. The iron test by low induction consists in inducing an induction in the 0.04-0.06 T range and determining the eddy currents produced by the possible faults. The advantage of this method is that it does not require supply from great power sources and enables the more precise detection of faults, even if they are deep in the stator core. The paper describes this method. The theoretical bases and the evaluation criteria are also presented. Further, a comparison between the two methods, the high induction and the low induction one, based on a concrete case is made. Finally, a series of results of the diagnosis measurements of the stator cores of certain turbo and hydro generators from the National Power System are presented.**

**Keywords:** stator core, electric generators, iron test, low induction

## 1. INTRODUCTION

The stator core of the electric generators is made up of a great number of thin iron sheets (laminations) with oriented crystals (cold laminated), insulated one from another in order to diminish losses due to eddy currents (Foucault). The sheet assembly is strengthened by a system of wedges that go through the stator yoke and rings or pressure plates. During operation, due to the thermal, mechanical (vibrations) and magnetic stresses, minor faults of the insulation between the sheets deep in the core may occur as a result of the ageing effects causing sheet short-circuiting. At the same time, mechanical accidents (impacts, frictions) that may cause short-circuit in the part towards the air gap of the sheets may occur. These minor internal or surface faults can lead to a significant increase in the eddy currents circulating in the respective area that will cause dangerous heating increases leading even to iron melting and destroying insulation of the adjacent stator bars.

Stator core faults can be detected only with the rotor taken out, either by means of the high induction or the low induction methods.

In principle, the high induction method consists in exciting the stator core by a magnetic induction of about 80% of the rated induction, 1 – 1.4 T respectively, and detecting the faults in the iron by their thermal effect; at the fault location there occurs a high local heating in comparison with the average temperature of the rest of stator core. At present, the measurement of the core heating is performed by means of the infrared measurement devices. The method has a number of disadvantages among which the fact that it requires a high power supply source for supplying the excitation winding made up of several windings of a cable adequately dimensioned so that to correspond to the used current that is difficult to get and handle. For example a 330 MW turbo generator, or a 50 MW hydro generator, require a transformer of about 4 MVA, 6.3 kV. At the same time, the heating determination should be performed very quickly so that the former do not disperse and for avoiding the possible expansion of the existing faults or the occurrence of new ones as during the test the core is not ventilated. Another disadvantage is limitation of detection, mainly of the surface faults and the fact that it is practical impossible to detect the faults that are located deeper in the slot walls or even in the stator yoke.

In principle, the low induction method consists in exciting the stator core by a magnetic induction of about 4 % of the rated magnetic induction in the stator yoke, 0.04÷0.06 T, respectively, and detecting the iron faults by means of the electromagnetic effect, using a measurement transducer of the “Chattock magnetic potentiometer” type. The test requires a 20-50 A adjustable supply source and the excitation coil is made up of several windings of the flexible connection cable of glazed copper, with a 6mm<sup>2</sup> cross section, insulated with PVC. At the same time the method enables the detection of the superficial faults of the stator core, but also of those on the stator teeth or at the bottom of the slots or in the stator yoke. During the test no heating of the iron occur.

## 2. THE THEORETICAL BASIS OF THE LOW INDUCTION THEORY

The low induction method for performing the iron test is based on the law of the magnetic circuit (Ampere's theorem), applied to a closed contour including a part in the iron with a fault, and made up of two adjacent teeth and the adjacent stator yoke and a part through the air (fig.1). The fault current  $I_d$  circulates perpendicularly to the sheet plane.

$$\int_{\Gamma} H dl = \int_{\text{air}} H_{\text{air}} dl + \int_{\text{iron}} H_{\text{iron}} dl = I_d \quad (1)$$

As iron magnetic permeability is very high in comparison with that of the air, the term through the iron can be disregarded:

$$I_d = \int_{\text{aer}} H_{\text{aer}} dl \quad (2)$$

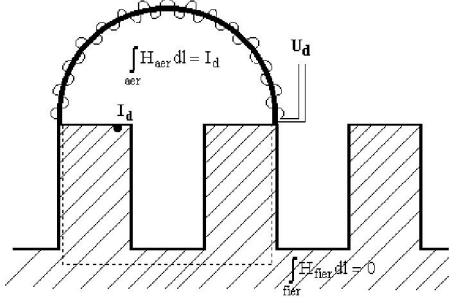

**Fig. 1. Chattock potentiometer position on the stator teeth**

The Chattock potentiometer consisting of a long thin solenoid, wired with very thin copper wire on a non-ferrous flexible support, enables the measurement of the magnetic potential difference between the farthest corners of the adjacent teeth, the electromagnetic field produced in the air by the fault current, respectively.

The excitation winding placed on the stator as in fig. 2 is supplied and traversed by the excitation current  $i_e$  that generates a magnetic flux with circumferential circulation, variable with time. This variable with time flux induces the voltage  $u_e$  in the stator iron along its length:

$$i_e = \sqrt{2} I_e \sin \omega t \quad (3)$$

$$\varphi_e = \sqrt{2} \Phi_e \sin \omega t \quad (4)$$

$$u_e = L \frac{di_e}{dt} = \sqrt{2} \cos \omega t \quad (5)$$

where  $L$  is the core inductivity.

As the core is entirely non-saturated, the dispersion inductivity can be considered null.

The fault current (perpendicular to the faulty sheet plane) generates a reaction flux - the fault flux  $\Phi_d$  -, that is in phase with this current. The fault flux induces a voltage in the fault area considered as a series circuit:

$$u_d = \frac{l_{Fe}}{l_d} u_e = R_d i_d + L_d \frac{di_d}{dt} \quad (6)$$

where:  $l_{Fe}$  is the length of the stator core  
 $l_d$  - length of the fault zone  
 $R_d$  - resistance of the fault zone  
 $L_d$  - inductivity of the fault zone  
 $i_d$  - fault current

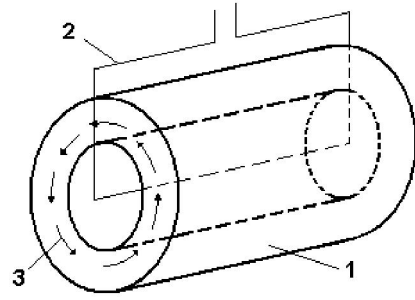

**Fig.2. Excitation winding positioning  
1-stator core; 2-excitation winding;  
3-circumferential induced flux**

Solving the RL fault circuit for the fault current there results the expression:

$$i_d = \sqrt{2} \cdot \frac{l_d}{l_{Fe}} U_e \frac{R_d \cos \omega t + \omega L_d \sin \omega t}{R_d^2 + \omega^2 L_d^2} \quad (7)$$

and as  $R_d \gg \omega L_d$ , the terms  $\omega L_d$  can be overlooked

$$i_d = \sqrt{2} \frac{l_d U_e}{l_{Fe} R_d} \cos \omega t \quad (8)$$

The fault current  $i_{dq}$  is in the phase quadrature with the excitation current  $i_e$  (fig. 3)

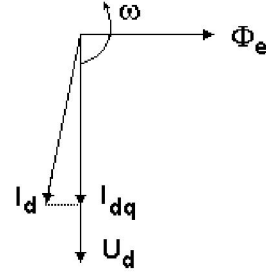

**Fig.3. Phasor diagram  
 $\Phi_e$  - flux generated by the excitation current ;  
 $I_d$  - actual fault current;  $I_{dq}$  - fault current in  
the quadrature;  $U_d$  - voltage induced in the  
faulty sheets**

The reaction flux (fault flux) produced by the fault current, in phase with the former and, therefore, in quadrature with the excitation current is summed up with the flux produced by the excitation current, in phase with it. This total flux will induce a voltage of the following form in the Chattock coil:

$$u_c = \sqrt{2} \omega \sqrt{\Phi_e^2 + \Phi_d^2} \sin (\omega t + \arctan \frac{\Phi_e}{\Phi_d}) \quad (9)$$

Through the coil without iron core of the potentiometer will circulate a current of the form:

$$i_c = \sqrt{2} I_d \sin \omega t + \sqrt{2} I_e \sin (\omega t - \frac{\pi}{2}) \quad (10)$$

Even if there is no fault present, in the measurement transducer a high value voltage is nevertheless induced due to the excitation magnetic flux; in the presence of a fault, the excitation flux is much higher than the flux of any fault current that could be detected. This voltage is eliminated by a phase detector that measures the instantaneous amplitude of the voltage induced in the measurement transducer when the excitation flux passes through zero; this represents the very fault voltage amplitude.

In these conditions, besides the signal from the measurement transducer, a second signal to indicate the phase of the excitation magnetic flux is required. This signal is given by a reference coil (with the magnetic core of sheets) that is fixed by means of permanent magnets inside the stator core so that to short-circuit the excitation magnetic flux from between two adjacent teeth.

### 3. THE MEASUREMENT AND DIAGNOSIS METHOD

The excitation winding of the stator core is made in the following way:

- for turbo generators – the concentrated - winding type, made up of a single bundle of about 7 wire turns; in the interior part of the stator the excitation winding should be positioned in the middle, along the longitudinal axis, by means of some supporting insulating elements; in the exterior part of the stator the bundle of wire turns is positioned by (along) the casing.
- for hydro generators – the distributed winding type, in 3÷6 equidistant bundles of about 7 turns of wire according to the size of the hydro generator stator and the excitation current necessary for obtaining a 4% induction from the rated induction; in the interior and the exterior part of the stator the bundle of wire turns is positioned by the core and the casing, respectively.

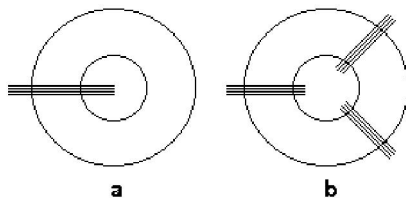

**Fig.4. Positioning of the excitation winding**  
a – for turbo generators; b - for hydro generators

A measurement winding with only one turn of wire, whose route is parallel to the route of the excitation winding that is connected to an AC voltmeter is performed for measuring the excitation voltage  $U_e$ .

A reference coil is fixed directly to the iron core on the iron gap side, to an end so that to short circuit two adjacent teeth. It is a small-size coil, with ferromagnetic core, that will supply a reference voltage in phase with the excitation flux.

A Chattock measurement transducer of an adequate length chosen so that to include two teeth between its extremities is fixed on a wheel chart with an adjustable transversal distance that enables its movement on the

adjacent teeth. On the same wheel chart there is also a position transducer.

By means of the Chattock transducer an operator will scan in turn each pair of teeth corresponding to a slot in longitudinal direction. In the hydro generators case, the slots are scanner in the zones between the excitation coils (up to a distance of minimum 10 slots against the coil). Then, the position of the three excitation coils is changed and the rest of the slots are scanned. In the hydro generator case there is also the issue of the parallel separation planes between the stator sectors (if the latter is designed accordingly). Due to the deformation of the excitation flux when crossing the separation the planes through the increase in the leakage flux this will have higher values and, thus, the measurement transducer will implicitly measure higher values. That is why the slots where the separation planes are positioned will be scanned separately.

The signals from the Chattock transducer are processed by conditioning equipment (signal amplifier with variable amplification and filtering block), are acquired and processed by a laptop by means of the virtual instruments and display the fault current or voltage values and the corresponding position in graphical and numerical form.

The measured values should be measured and analyzed by the value and form of the registered signal by comparison between two adjacent teeth for identifying the existing faults.

In the absence of any faults, the form of the signal is flat, with no peaks, and the current values range between 0 and +/- 20 mA and the voltage between 0 and +/- 50 mV.

In case of a fault occurrence, the signal is peak-shaped (pulse), positive or negative, and has values higher than 100 mA, 250 mV, respectively. These values correspond to an overtemperature higher than de 15 °C against the average value of the core area, generated by a fault, during the high induction test.

Fig. 5 and 6 presents the basic forms, standard for the signals that indicate the presence of a fault in correspondence with fault location. According to the shape and polarity of the signal the fault can be located on the surface or deep in the tooth, in radial direction as follows:

- the positive polarity signals and the similar amplitude for the slots delimiting a tooth (slots 3 and 4) indicate a fault on the tooth top (A)
- signals of opposite polarity and similar amplitude for the two slots delimiting a tooth (slots 3 and 4) indicate a fault on the side of the tooth under the corner (B) towards the spot with positive signal
- positive signal on only one spot of the two delimiting a tooth (slot 4) indicates a fault on the wall of the tooth near to its basis (C)
- negative polarity signals and similar amplitude for the two slots delimiting a tooth (slots 3 and 4) indicate a fault in the stator yoke in front of the spot with the highest amplitude (D)

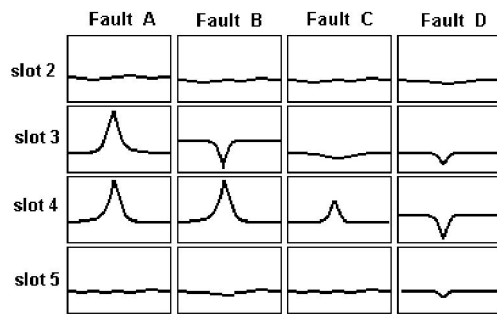

Fig.5. Basic forms of the Chattock signal

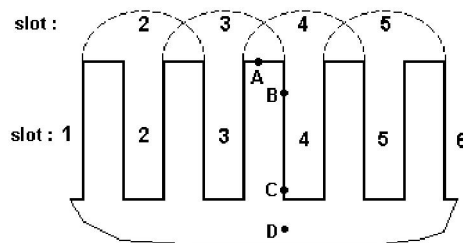

Fig. 6. Fault location

#### 4. COMPARATIVE MEASUREMENTS BY MEANS OF THE TWO METHODS: LOW AND HIGH INDUCTION

In 1997, a powerful blow on the tooth between the slots 57 and 58, stack 12, was noticed at a vertical 90 MVA, 15.75 kV, 600 rot/min, 180 slots, 40 stacks of sheets ( $I_{Fe}=2140$  mm) hydro generator, after the rotor had been taken out after a connection to the stator frame. The stator core was verified by means of the low induction method at the institute ICEMENERG and by the high induction test at the manufacturer's. The low induction test was performed by an induction of 5% of the rated induction, a new method at the time, while the induction used with the high induction method was 1.4 T.

Fig.7 presents the diagrams for the surface fault in the case of the low induction method.

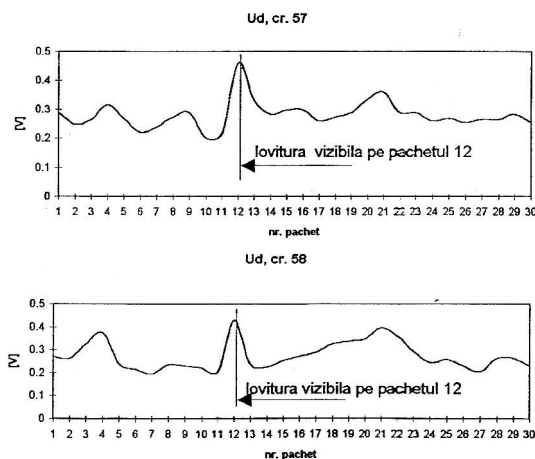

Fig 7 Diagram of the surface fault,  $U_d=f(\text{stack no.})$  for the low induction test  
 ← Visible blow on the stack 12

The diagram points out the fault voltage on the two slots is positive and it measures 480 mV (the value of the excitation voltage was about 150 mV). Fig.8 presents the

infrared photograph of the same fault by means of the low induction method.

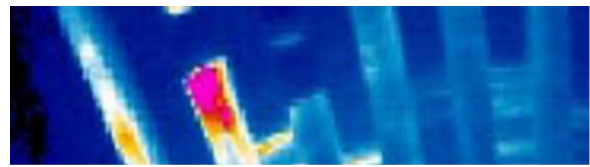

Fig. 8. Infrared photograph of the surface fault, high induction test

On this occasion, it was noticed that during the low induction test the majority of the frontal sheet stacks from the upper and lower part of the generator displayed fault voltages in the 300- 500 mV (fig.9) range, a fact that was confirmed by the high induction test (fig.10).

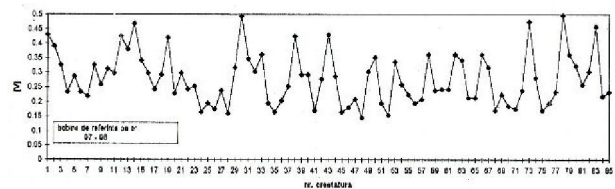

Fig.9. Diagram of frontal stack faults,  $U_d=f(\text{no. of slots})$ , by low induction method

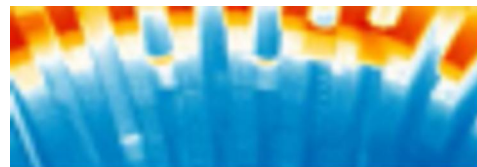

Fig 10 Infrared photograph of the frontal packages during the high induction test

During the visual inspection of the respective sheet stacks, it was noticed that the paint on the pressing fingers was burnt and that they, as well as partially the sheets under them had oxidized in the retracted step area. It was also noticed that the pressing fingers had been manufactured of magnetic steel instead of non-magnetic. When the generator was in operation, the pressing fingers got very hot due to the axial magnetic field existing in the area, heat that was transmitted through conduction to the teeth that they were pressing on and therefore deteriorating the insulation of the respective stacks.

During the low induction test another fault in the stator yoke was detected.

#### 5. EXAMPLES OF FAULTS DETECTED IN THE GENERATOR STATORS EXISTING IN THE NATIONAL POWER SYSTEM

In the course of time, numerous tests of the iron by means of the low induction method have been made. The tests were performed on different occasions:

- prophylactic, during maintenance works of the 4 or 3 levels or after breakdowns of the stator winding
- when some blows are detected on the stator core on the side towards the air gap before and after the repair.

As regards the prophylactic tests, the verdict was “no faults in the stator iron” in most of the cases.

Nevertheless, faults on the slot wall or at the bottom of the slot have been sometimes detected. Most of the faults in the iron are caused by the blows given by parts that have detached from the rotor, such as the balance weights, nuts, etc. or blows that occur when the rotor is taken out, due to balancing or friction.

### 5.1. Fault on the surface of a 60 MW turbo generator (Gomorra CHP plant)

The fault occurred during taking out of the rotor when it hit the stator when it balanced, crushing 10 sheet stacks from 3 teeth. Table 1 presents the teeth with the deteriorated sheet stacks, the maximum value of the fault voltage and the corresponding equivalent temperature.

**Table 1**

Tooth between slots	Stack no.	$U_{\text{fault max}}$ (V)	$T_{\text{equivalent}}$ (°C)
42 - 1	2 - 4	0,600	17 - 36
1 - 2	4 - 5	0,350	17 - 21
6 - 7	3 - 7	0,600	17 - 36

Figure 11 points out that the fault on the tooth between the slots 1-2 is smaller than the faults on the teeth between the slots 42-1 and 6-7.

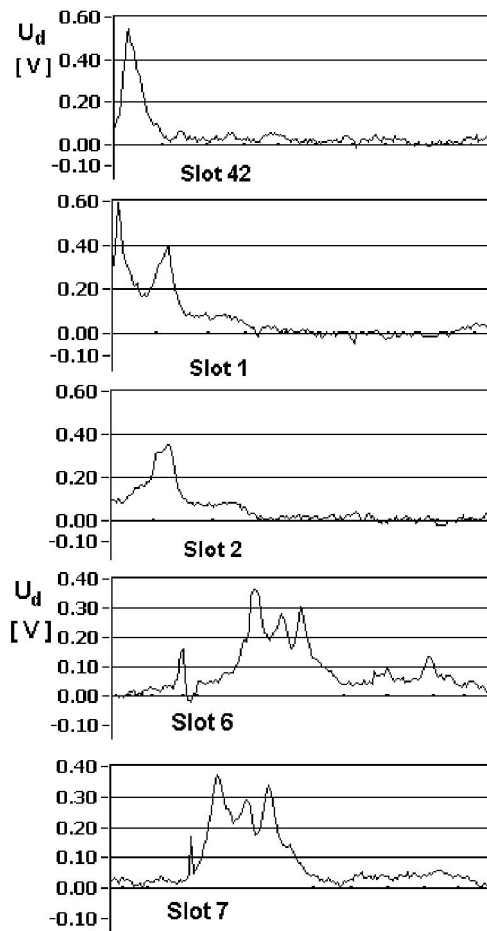

**Fig.11. Diagrams of the surface faults at TG 60 MW**

### 5.2. Fault at the basis of the slot of a 60 MW turbo generator (Palas CET)

During a prophylactic test, a fault at the tooth basis was detected. The stator bars were taken out from the respective slots and a molten thermoresistance that had short-circuited the sheets at the basis of slot no. 1 was found.

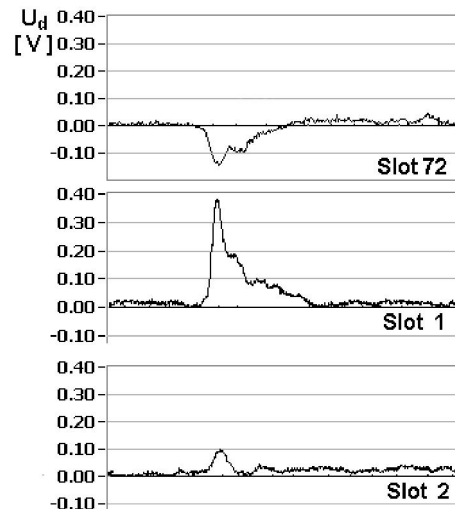

**Fig.12. Diagrams of a surface fault at a 60 MW TG**

### 5.3. Fault in the separation plane of a 75 MW hydro generator (Mărișelu HPS)

During a prophylactic test a fault in the separation plane from slot 30 (fig.13) was detected. In the case of the separation, excitation voltage is also noticed (in the quadrature with the fault voltage and which is usually eliminated). If there are faults in the separation faults (fig.14), the fault voltage has the same aspect as the excitation voltage. If a fault is detected, the fault voltage has peaks that do not appear in the case of the excitation voltage.

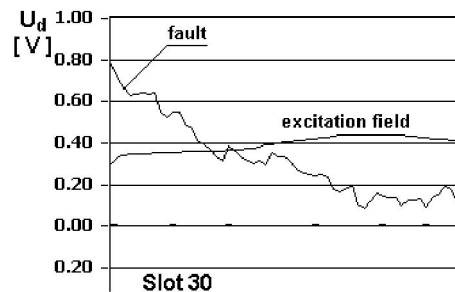

**Fig.13. Diagram of the separation plane fault of a 75 MW HG**

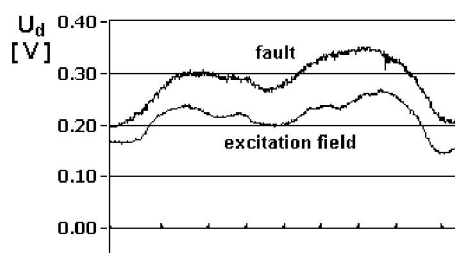

**Fig.14. Diagram of a faultless separation plane**

## 6. CONCLUSIONS

The low induction method is simpler, easier to use and enables both the detection of the deep tooth faults and of the stator yoke ones. The method can be used for the fault repair monitoring without disturbing the repair works.

The high induction method is more difficult to use as the test preparation presupposes handling of high voltage cables that are heavy and long and of the power transformers. The measurement itself is simple and can be performed by means of an infrared sighting apparatus. Moreover, this method does not detect only the surface faults. After the test completion a long period of time is required for the core to cool.

## REFERENCES

- [1] Ridley K.G., *Hdrogenerator stator core condition on EL CID results*. Proceeding of an EPRI International Motor & Generator Predictive Maintenance & Refurbishment Conference , Nov.1995
- [2] Zlatanovici R., Zlatanovici D.,Oprea T., Ivan M. *Monitoring and diagnosis method for laminations made magnetic cores status*, Travaux du premier atelier scientifique franco-canadiano-roumain, Bucarest, UPB,1997 , rap.IB-2
- [3] Ridley G. K, *Hydrogenerator EL CID results referred to High Flux Ring Test results* Rap CIGRE 11-201, 2002
- [4] G. Klemper, *EL CID (Electromagnetic – Core Imperfection Detector) Testing of Large Steam-Turbine-Driven Generators*, Technical Raport , SC 11, 2003
- [5] Stone G.C., Boulter E.A., Culbert Ian, Dhirani H. *Electrical Insulation for Rotating Machines*. Publishing House IEEE Press,USA, 2004, 372p, ISBN 0-741- 44506-1
- [6] Bertenshaw David, *Analysis of stator core faults - a fresh look at the EL CID vector diagram*, Proceeding of Hydropower & Dams, Oct 2006
- [7] Ridley K.G., *EL CID – Application and Analysis*, ADWEL International Ltd, Copy TECHUK Ltd, Great Britain, The third edition, 2007, 150 p
- [8] Connolly Neil, *Guide for Generator Overfluxing*, CIGRE Study Committee A1, WG A1.01, 2010