

# RUNNING ONE HYDROELECTRIC POWER PLANT WITH POMPED STORAGE FACILITIES USING INFORMATIC SYSTEMS

Basarab Dan Guzun, Elena Iuliana Anghel\*

\* Polytechnic University Bucharest

**This paper is trying to present the way in which the hydrogenate speed can be determinate by the levels in the two lakes of the complex, the upper lake and the lower one. Those levels are determined by measurements with modern GPS systems. The advantage of this system is the yield maximization for the energy facilities if it works with variable speed. This study is very useful for a Hydroelectric Power Plant with Pumped Storage that will be built in Romania at Tarnita-Lapustesti.**

**Keywords:** Hydroelectric Power Plant, storage system, different leveled lakes, pumps units at variable speed, synchronous generators and motors, asynchronous starting, back-to-back supply, islanding conditions

## 1. INTRODUCTION

Improving the functions conditions of power plants in terms of increased reliability, availability and maintainability is an important issue. In recent years, the increased interest is directed for surveillance and diagnostic facilities for all the electro energetic components based on computer support process, and whether due to the multitude of communication solutions for the market and versatility automation equipment, control and surveillance. This interest is motivated by the needs to reduce the maintenance costs and improve reliability of power energy production processes.

Because of the technologic progress the real time industrial process control has become easier for most complex processes. An important role is played by intelligent adaptive, auto adaptive and expert systems. Results of using these systems are a very good flexibility and extensibility.

This study has three parts. In the first one, the authors try to demonstrate the real and consistent advantages for one high power pumping station PPS designed for storage energy facilities if it works with variable speed to better fulfill its energy storage tasks. Now the those hydroelectric aggregate are operating at a constant speed but a higher efficiency is to be expected at a variable speed, along with a lower energy consumption, reliable working at lower speeds and a better computer control.

The second part tries to demonstrate that the energy balance is close to keep without disturbing the upper high voltage national electric power grid, within the suggested operation via back-to-back supply scheme, from the remote generating hydro-electric power plant HPP working with variable speed, at islanding conditions.

The third part is clearly stated that, within some

minor modification on the remote generating side, one hydro power unit could remain connected to the fixed frequency power grid as before, while the other one is to operate at a variable speed imposed by the maximum efficiency hydraulic constraints of pumping operation following these modified hydraulic conditions.

## 2. THE CONTENT OF THE WORK

The operation of a hydraulic pumping system may be described in stationary regimes based on plotting of head-capacity curves. The rated head and rate of flow is obtained by the intersection of the pump curve by the maximum efficiency with those from the hydraulic network. This optimal designed situation reflects the best mass and energetic equilibrium.

For operating in different regimes required by the user there are various modalities to control and adjust the hydraulic system. Traditional adjusting method for the output of the pump, with constant speed is through throttling the discharge valve of the pump. This method is dissipative with energy loss and less efficiency for the pumping system. The new concept of control method proposed here is through changing the rotational speed of the pump achieving the final regime with minor reduction of efficiency in respect of the best efficiency initial regime.

If the control is slow, the quasi-static approximation of the transients is valid. Using the proposed method the new stationary regime of the pumping system has effectiveness, namely a gain; which depends on the inclination of the long axis of the equal – efficiency curves and also from the steepness of the network curves.

The peculiarly of the hydraulic system studies here is that the network is changing not by throttling but with level differences between the reservoirs. So the classic gain in efficiency is higher if the above mentioned axis is more inclined from the vertical direction in head-capacity coordinates and if the configuration of the network head-capacity curve is steeped. These conditions are relaxed in the case studied here.

## 3. THE FOCUSED CASE

The case study refers to a Romanian hydro-power system a part on which is represented in figure 1.

The essence from the hydraulic pumping system is represented in figure 2. The hydraulic pumping system consists of the pumping station and the hydraulic network.

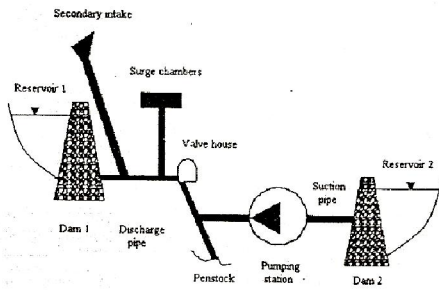
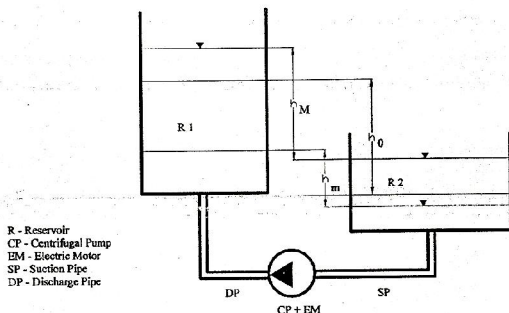

**Fig. 1. The forward part of a hydro power system**

The main parameters of the pumping station are:

- a) CP – centrifugal pumps, concrete 2 pumps operating in parallel, each with two stages and double entrance. The design parameters each pump are:
  - Capacity  $Q_0 = 3 \text{ m}^3/\text{s}$ ;
  - Head  $H_0 = 274 \text{ m, H}_2\text{O col}$ ;
  - Rotation speed  $n_0 = 1000 \text{ rev/min}$ ;
  - Pump efficiency  $\eta_0 = 90\%$
- b) EM – synchronous electric motor, asynchronous start;
  - SP – suction pipe with the cross-section of  $1.92 \times 2.76 \text{ m}^2$ , and the length  $L_2 = 6500 \text{ m}$ .
  - DP – discharge pipe with the cross-section  $\Phi D = 1.3 \text{ m}$ , and the length  $L_1 = 360 \text{ m}$ .

The rated level differences between the reservoirs is  $h_0 = 241 \text{ m}$  (figure 2).



**Fig. 2. Essential elements of a Hydraulic Pumping System**

The maximum and minimum allowed levels differences between the reservoirs are:  $h_M = 253 \text{ m}$ ;  $h_m = 198 \text{ m}$ .

The values are given as initial input design data.

The characteristic diagram  $Q-H-n-\eta$  for the two identical centrifugal pumps operating in parallel is partially plotted in Figure 3.

The input power for driving the pumps is a function of discharge and rotation speed as determined by the similitude extrapolation formula:

$$P = (n/1000)^3 * (1.213Q + 8.87) \quad (1)$$

Where:  $P$  is the power input, [MW],  
 $n$  – the rotational speed, [rev/min],  
 $Q$  – the discharge, [ $\text{m}^3/\text{s}$ ].

The intermittent operation of the hydraulic system is the feeding of the reservoir R1 from the reservoir R2. Depending on the consumption during this process, the water goes from R2 into R1.

The Eq. (1) mostly has a qualitative importance and is justified from the value of the pump impeller specific speed:

$$n_s = n(Q_0/2)^{1/2} (H_0/2)^{-3/4} = 71.75 \text{ rev/min}$$

The extreme speeds of rotation, necessary for the optimum operation of the pumps, are determined as follows.

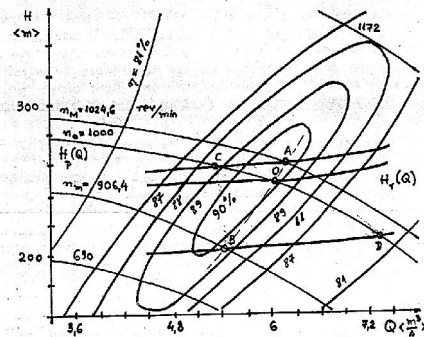
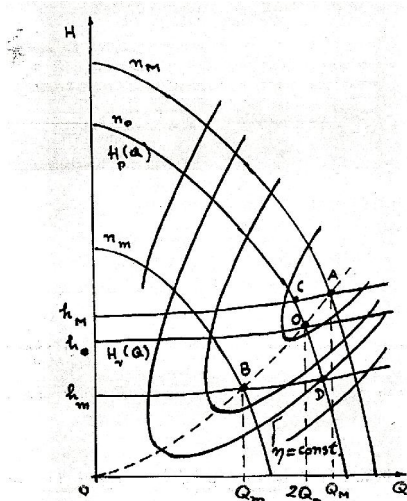

**Fig. 3. A Sequence of the Characteristics Curves of the Two Centrifugal Pumps in Parallel.**

Qualitatively, what will be calculated starting from the rated regime to the extreme regimes (for maximum and minimum level differences of the reservoirs), is represented in figure 4.

**Table 1. Main characteristics of the Two Pumps, Parallel Working**

Point	Regimes	H [m]	Q [ $\text{m}^3/\text{s}$ ]	$P_a$ [MW]	$P_{abs}$ [MW]	H [%]	N [rev /min]
0	Rated	247	6	14.538	16.118	90.2	1000
A=M	Variable speed	259.3	6.148	15.639	17.338	90.2	1024.6
B=m		202.9	5.438	10.824	12.094	89.5	906.4
C=M	Constant speed	257.7	5.3	13.398	15.127	88.57	1000
D=m		210.9	7.323	15.153	18.419	82.27	1000



**Fig. 4. Explanatory Plotting Head-Capacity-Speed Efficiency of the Pumps within the network**

Knowing the rated regime parameters of the hydraulic network namely the head  $H_0 = 247m$  and the discharge in the pipes  $2Q_0 = 6 m^3/s$  the constant  $C$  of the network is given by:

$$H_r = h_0 + C(2Q_0)^2 = H_0 \quad (2)$$

The value obtained is  $C = 1/6 s^2/m^5$

Taking into accounts the turbo-machine similitude formulae:

$$Q = k_Q n \quad (3)$$

$$H = k_H n \quad (4)$$

The calculus of the parameters of the extreme regimes implies solving the set of Eqs. (5), (6) and (7), and respectively (8), (9) and (10):

$$H_m = (H_0 / (2Q_0)^2) Q_m^2 \quad (5)$$

$$H_m = h_m + CQ_m^2 \quad (6)$$

$$n_m = (n_0 / Q_0) Q_m \quad (7)$$

For which the results are: discharge  $Q_m = 5.438 m^3/s$ , head  $H_m = 202.929m$ , and speed  $n_m = 906.4 rev/min$ .

For

$$H_M = (H_0 / (2Q_0)^2) Q_M^2 \quad (8)$$

$$H_M = h_M + CQ_M^2 \quad (9)$$

$$n_M = (n_0 / Q_0) Q_M \quad (10)$$

The results are:

discharge  $Q_M = 6.148 m^3/s$ , head  $H_M = 259.299m$ , and speed  $n_m = 1024.6 rev/min$ .

Analyzing the universal characteristics of the pumps, figure 3, it may be interpolated and estimated the corresponding efficiencies and power, they are given in the Table 1.

The approximate maximum efficiency gains are  $\Delta\eta_{AC} = 1.63\%$  and  $\Delta\eta_{BD} = 7.23\%$ . These values give a measure of the effectiveness of the speed control as compared to the operation at constant speed or the throttling control of the pumps.

#### 4. THE POWER ELECTRIC DRIVING SYSTEM

The power electric driving system, shown in Figure 5, provides the controlled variable speed for pumps, operates at specific hydro-constraints, and offers some remarkable advantages. However, the most important advantage remains the higher efficiencies over constant speed or throttling. It has to be mentioned the more reliable operation at lower speeds, plus a better computer-controlled speed variation for present operating conditions.

The method of speed control over the hydraulic turbo machine may be used in any hydraulic system, especially for a higher power rating.

The electric power- at variable frequency is to be power plant HPP, operating in this particular case with one single generator rated at 24 MVA, 10/110 kV, under island-operation conditions, injects its output via its second distinct electric overhead line, LEA 110 kV.

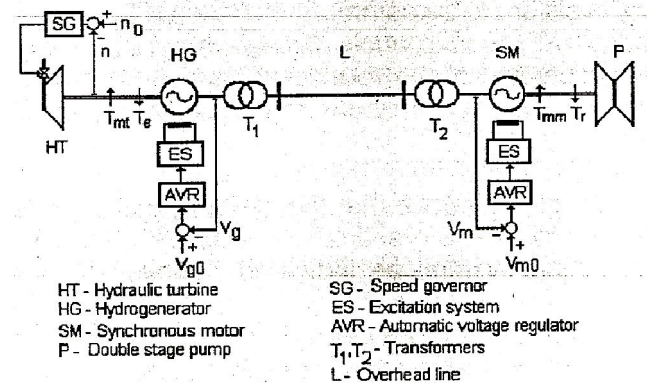

**Fig. 5. The Simulated Power System**

The other Hydro-generator HG of the HPP could remained connected to the system at a fixed frequency; the two units are to be separated by one coupling cell deliberately introduced in the scheme in order to gain elasticity for the new operational regimes.

The power pumping station PPS rated at 2x10 MW, 110/6kV, 2x3 m<sup>3</sup>/s, 1000 rev/min is located at a distance of approximately 30 km, up the mountain; it is loaded according to the specific hydraulic conditions given by the levels of the two reservoirs, of small and large capacities l, and L.

The two levels are to be communicated via GPS to the basic HPP, and the whole driving system power electric energy is operated at the requested variable frequency, in order to gain the overall maximum efficiency for the PPS in question.

The same specific Hydraulic conditions impose the practical spectrum of speeds to the electric driving system. The speed limits are non-symmetrically scaled and range from 906.4 to 1024.6 rev/min, more below than above the synchronous speed of 1000 rev/min.

This speed of 1000 rev/min was imposed by the frequency of the national electric grid, 50 Hz, but is not the best solution for the PPS operating in these specific hydraulic challenging conditions.

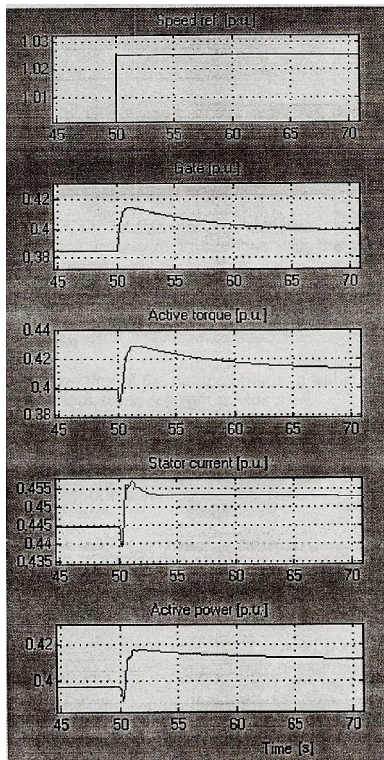

**Fig. 6. The transients on the Hydro-Generator Side**

The results in Figure 6 provided by the simulations are based on the standard synchronous machine equations. So, one average small step of 10 rev/min or equivalent 3 % increased in seconds the hydro generator HG speed. The remote motor has slower response, reaching its upper speed limit with a certain delay; witch is not higher than 10-15 s.

On the HG side (Figure 6), the increased active torque promptly increases the stator current and the active power injected at the terminals.

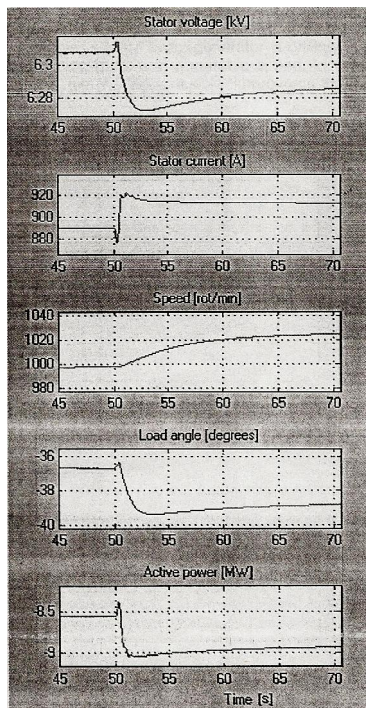

**Fig. 7. Synchronous Motor Transits**

## 5. THE POWER HYDRO-ELECTRIC SIMULATION RESULTS

On the motor side at the PPS (Figure 7), as a result of the prompt command for an increased frequency coming from HG via 110 kV line, the same prompt responses are evident for the increase of the stator current and absorbed active power and for the drop of the stator voltage.

The discussion over the simulated behavior, for the first time, in this particular back-to-back high power scheme running at variable speed and exploiting the local favorable conditions, this exercise proves to be a successful one.

## 6. CONCLUSIONS

The speed control of the pumps operating within hydraulic systems, offers some relevant advantages:

- higher efficiencies than the ones specific to constant speed or throttling;
- reliable operation an lower speeds;
- better computer-controlled
- pre-set operating conditions (head or discharge flow).

This application has certain unique local conditions covering vary difficult hydraulic conditions; witch also implies an impressive set of phenomena.

Throughout the world of hydro power engineering, the important HPPs with storing facilities operate at variable speed, and underline other advantages brought along by this method. On a world-wide scale, different electric driving schemes are used, but the most elegant are those with frequency converters/soft starters and especially the AC cyclo-converters

The present paper presents the cheapest possible and independent back-to-back driving ashamed, in witch one down-stream hydro-generator is driving the up-stream pumping motors at a variable speed, in order to demonstrate firstly the possible improvements in the overall pumping efficiency, and secondary to exploit the favorable local conditions, with minimum modifications.

## REFERENCES

- [1]. Sulzer, "Centrifugal Pump Handbook", Winterthur, 1987
- [2]. R. MacKay, „Variable speed, Pumps and Systems”, 2004
- [3]. V. I. Arnold, Metodele matematice ale mecanicii clasice, Editura Științifică și Enciclopedică, București, 1980
- [4]. B. Guzun, C. Mucichescu, Optimal high Power Pumped-Storage System, Torino, 2006