

# TECHNOLOGICAL MODELLING AND TRAINING OF THE ENERGY PERSONNEL THROUGH ENGINEERING SYSTEMS

Prof. PhD.eng. Gheorghe Lazaroiu, University Politehnica Bucharest, glazaroiu@yahoo.com

**Abstract:** *Engineering systems suppose the achievement of intelligent simulation network in real time for high power energy blocks. The implementation of the block, of the base software and of the application software on a dedicated computer network is accomplished. Engineering systems are destined to professional training of the exploitation personnel from the thermal power station (formation, training, testing). The accomplishment of the system demands the resolution of various problems: scientific nature (technological processes modeling specific to the circuits and installations), informatics nature (software packages afferent to the basic software and application software), assembling and integration of the upper software towards the simulation of the operating conditions afferent to real installations (normal, damage).*

**Keywords:** simulation, energy, training.

## 1. INTRODUCTION

The continuous increasing of the automation degree of the energetical installations, the improvement of the equipment reliability are implicitly leading to reduction of the manoeuvre number executed in exploitation and, consequently, to the necessity of additional training of the operative personnel of these installations both for the operating duty exploitation and for the emergency operation. The possibility of systematic practise of the manoeuvres executed in installations, without affecting the operation of the real installations, constitutes an efficient way of continuous training of the operative personnel. Thereby it was born the idea of engineering systems that through the accomplishment of some intelligent real time simulation networks for high power energy blocks responds to the training needed. The implementation of the mathematical stationary and dynamic models of the block, of the basic and application software is accomplished on a dedicated computer network.

It is required the treatment of some theoretical complex problems in the fields of stationary and dynamic models elaboration, of the automatic systems control, of accomplishment of basic and application software. The final product of the research is takes shape through the implementation of the system on a support consists of a ensemble of computers, support that allows both the sistem testing and of the models and theory elaborated in industry, education, respectively in profile research.

The intelligent engineering systems for high power energy blocks that the reference has been made to is applied to the block constituted of the 300 MW turbine – generator unit, the 1035 t/h steam boiler, as well as of those additional installations.

The accomplishment of the system demands the resolution of the following problems:

- the modelling of the thechnological processes specific to circuits and installations of the 330 MW unit involving the observance of the design requirements;
- the accomplishment of a programmes package – development medium working under Windows, destined to graphic visualization of the mathematical models results, to these execution synchronization, manual or instructor modification of some control inputs towards of the simulation of some different operating conditions;
- the accomplishment of the modelling programmes of the thechnological processes with the observance of the requirements enforced by the development medium, the achievement of simulation programmes of some interlock, permissive and protection systems, typical to the simulated technological installations;
- assembling and integration of the upper mentioned programmes towards of simulation of the normal and emergency operation conditions, of the real simulated installations;
- operation validation of the system accomplished through values comparison of the simulated parameters with the vaues from the real installations.

## 2. Requirements for the elaboration of the binary and analogical models

Mathematical models for a certain process consist of mathematical expression of the functional relations between characteristic amounts that define a certain system. These mathematical models are reflecting the variation in time and space between the effect amounts and cause amounts.

In mathematical models are used batches of equations containing from differential equations until partial differential equations, their nature depending of the complexity of the modelled processes and the purpose of their use.

Layout and complexity of the processes of the 330 MW block on which is implemented the intelligent engineering system enforce that the entire process to be structured on technological modules. For each technological module are written the dynamic and stationary models and is tested the functionality and the accuracy of the results, both individually and assembly.

The entire technological system is structured in more modules, constituted from analogical processes models and from binary processes models, such as valves closing / opening, starting / stopping, electric motors, etc.

The system interface allows the operator and the pursuit in real time of the technological processes of the boiler-turbine block.

Through the adopted strategy for the interface on the system displays can be followed the specific exploitation block parameters and may intervene in the followed process through mouse action on certain buttons or cassettes on the display.

### 2.1. Analogue modules

For the reasons upper mentioned has been established the following modules that characterize the operation in stationary and dynamic regimes of the 330 MW unit and of the internal services: 330 MW turbine; turbine oil installation; condensation installation; vacuum installation; steam installation at the labyrinth; low pressure preheater (PJP); high pressure preheater (PIP); deaerator; turbine control engineering; generator unit; electric sub-station module; boiler-turbine steam connection module; water supply electrical pump; turbo pump; 1035 t/h boiler.

### 2.2. Binary modules

Binary modules are structured in: modules specific to actuatings; protection and signalization module; command module for drive motors; specific modules for realization of the interface of the system.

These modules accomplish the system interface with the user and allows the possibility to border the modules from the 1035 t/h boiler.

The main requirements that underlie the mathematical modules accomplishment for the simulation of the binary processes of the turbine – generator unit and internal charge are containing aspects regarding: actuating and command modes of the equipment afferent to the boiler; the signalling modes of the main parameters outcome from the analogical models; the operating modes of the protections afferent to the 330 MW unit and to internal services.

Inside of the objective that shall be accomplished will be simulated the main command, protection and signalling diagrams, that are necessary inside of the 330 MW unit operating and of its addition installations.

## 3. SYSTEM FUNCTIONS

### 3.1. Graphic interfaces view

The programmes package is written in the Visual C++ language, that ensures the operation of the programmes under WINDOWS operating system, and uses the facilities of the object oriented programming and ActiveXs. The programme package destined to graphic view performs the following categories of functions:

- *simulation functions*
  - calculating analogue mathematical models to determine the technological parameters at preestablished time spans ranging from 0.1 sec. to 1 sec. according to their importance; the modelling calculations cannot be interrupted by the execution of other simulation algorithms; the simulation programs covers states ranging from 0-100%, and will be tested in steady operating states, but especially in dynamic operating states;
  - processing the modelling algorithms for drives, signals, permits, and protections is performed before the modelling calculations and only on changing the state of one of the values processed by these algorithms;
  - all the binary or analogue simulation algorithms operate with a common database;
  - the simulation system can be in one of the states: simulation *start* (the binary and analogue simulation algorithms are processed), or simulation *stop* (the execution of all the algorithms ceases and the value of the database parameters freezes)
- *simulation state survey-change functions*
  - process state view by surveying on display the evolution of the simulated process by using the technological designs and control and signalling boards. On these graphic images, one can identify the operating states of the boiler, turbine and generator equipment, the values of the main technological parameters (pressures, flowrates, temperatures), preventive and failure signals, openings of the control valves, etc.

- simulating the manoeuvres by commands of changing the states of the equipment in the turbine installation or the boiler one (on/off/valve stop, on/off engine, increase/decrease control valve opening, automatic/manual engine, etc.)
- event protocolling; the function endures the memorizing and printing of all the events occurred (including the moment when they occur). The event protocol can be printed or can be viewed on display
- database inspection (analogue and binary parameters); one can read the momentous values of all the modelled parameters
  - simulation framework preparing functions
- state saving – the saved state contains simulated values in an operating state; the momentous values of the database are recorded on the hard disk of the computer
- state restoring – loading the database with a state containing values saved previously; this way one can start the simulation process from any state saved previously
- disturbance input; in any simulated situation one can change a series of parameters of the model that have the significance of disturbances or operating defects (valve binding, accidental engine stop, control valve failure, etc.)

### 3.2. Simulation application operating modes

Operating – training mode – runs the simulation programs for turbine, generator and boiler operation. In this working mode the user can give commands and can execute manoeuvres, and the system displays the analogue values and the equipment states according to the mathematical models, and the instructor can input the operating disturbances. The operating – evaluation session mode runs the simulation programs, and the user can give commands to the system. Besides, as related to the training mode, here the system records the pupil's activity in a pupil file in order to be able at the end to evaluate it, by comparing with the standard file saved previously, and executed by the instructor

The operating – running mode by which the application reads one of the recorded files and displays on the graphic interface the read data (analogue and binary values). In this working mode, the simulation programs are no longer launched in execution and the user commands are no longer taken over. The user has the possibility to survey the running of the record and to commute from one design to the other in order to survey the unfolding of the process.

## 4. DATABASE

The 330 MW unit simulation application uses a very large amount of data, organized in a database. Within it one performs a clear distinction between the binary and analogue values, the two categories being grouped separately.

The binary data (equipment states, signals, etc.) and the analogue ones (displayed parameter values, working values, etc.) are grouped in separate tables for the two categories of data. The most important fields in the tables containing analogue and binary values are the fields 'index', 'code' and 'text'.

Another important component of the database is the list of events. The database includes the information on the evaluation sessions, that are saved as the application use process runs.

## 5. GRAPHIC INTERFACE

The technological designs of the graphic interface of the working posts comprise equipment and execution elements specific of the turbine installations and 330 MW generator.

The representation of the graphic interface on the technological designs allows focusing on more information on a single display screen, having the possibility to execute concomitantly the manoeuvres on some active elements (pumps, valves, etc.).

Within these designs the user has an overview upon a certain installation circuit, having the possibility to command the execution elements, and to notice the variation of the values of the main modelled technological parameters.

On the designs the values of the main operating parameters of the 330 MW unit are displayed, thus the operator has the possibility to survey permanently their variation during as the modelled process runs.

The graphic interfaces contain salt buttons in other designs. The buttons allow the user to access easily the technological design he wishes to view at a certain moment, having quick ties towards the designs associated with it.

To carry out the graphic interface it was necessary to elaborate active and static graphic elements likely to have a symbolization as close as possible to the simulated element. Thus, graphic elements were carried out for: - static image elements (pipes, bends, branches, etc.); active elements – symbols (ActiveXs), for instance: valves, flaps, engines

The active elements allow taking over the commands executed by the user by means of command cassettes and convey this information to the mathematical model.

The command cassettes are viewed by left clicking the active element on the graphic element. The window opens automatically, as it contains the command buttons of the selected active element, as well as displayed values of the internal parameters of the modelled element, for instance for a regulating valve the following values are displayed: position, reference, deviation.

Carrying out the graphic interface took into account the information collected within the 3rd unit of the Rovinari power plant, a retrofit with Emerson equipment – Ovation system.

Thus, the images taken over from the interface of the technological process monitoring and control application at unit 3 were reproduced 95% in the simulator interface.

A few images are presented comparatively in the following figures.

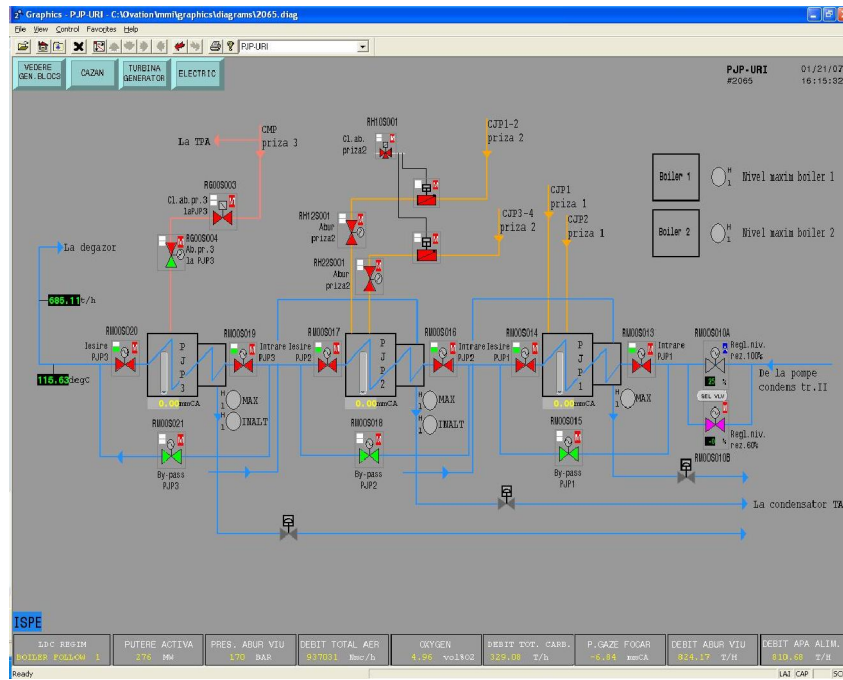

Fig.1. PJP circuit diagram – Ovation system.

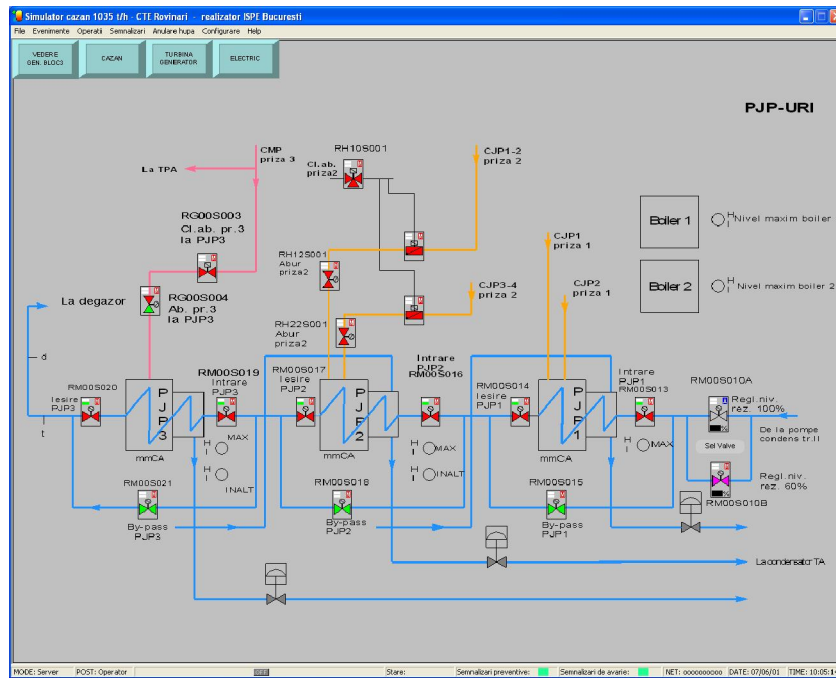

Fig.2. PJP circuit diagram – 330 MW group simulator.

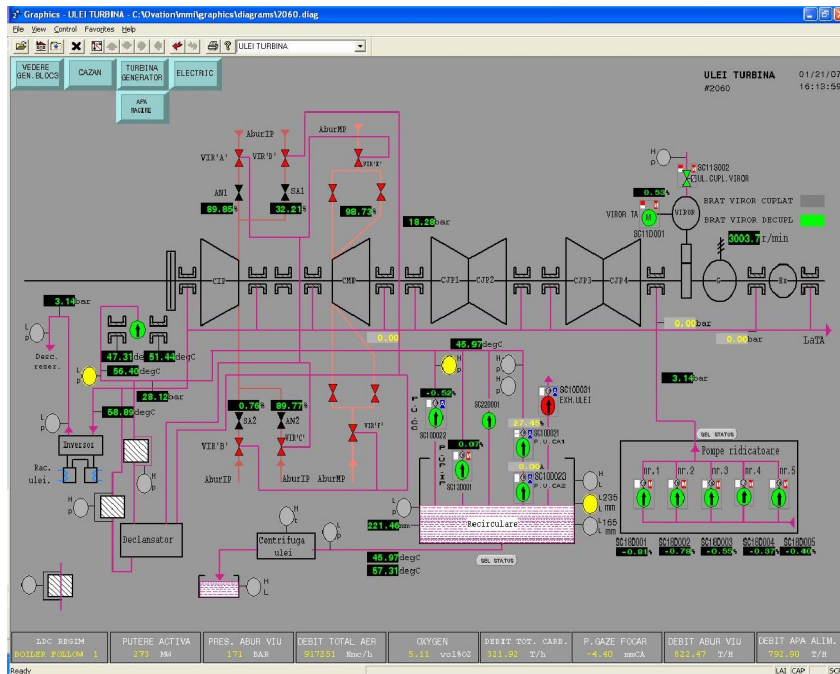

Fig.3. Turbine oil circuit diagram– Ovation system.

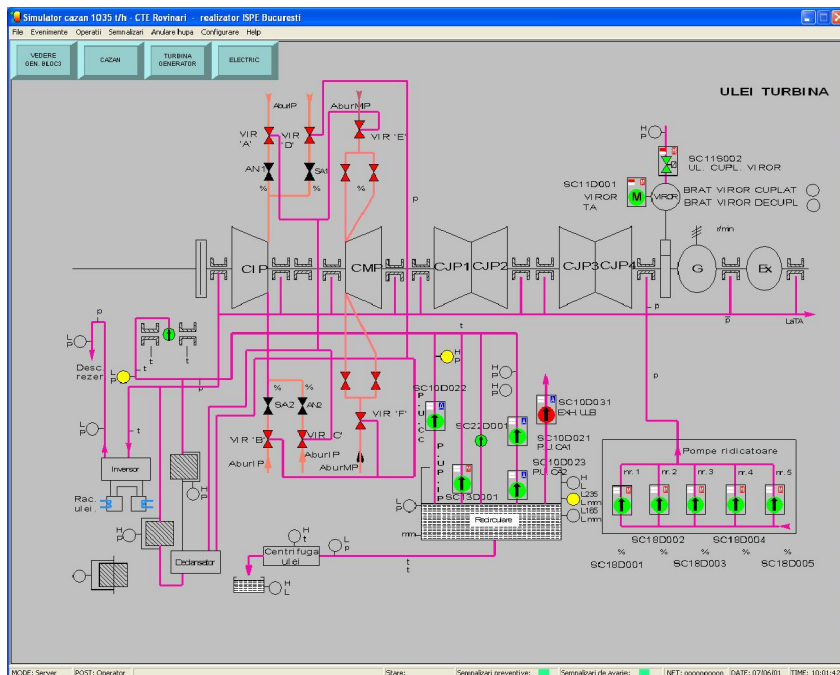

Fig.4. Turbine oil circuit diagram – 330 MW group simulator.

## 6.CONCLUSIONS

The most important aspects sustaining the carrying out and use of simulators in the operative personnel formation and training process in thermal power plants are the following:

- the very high values of the investments in power plants entail the necessity to use a highly skilled personnel
- the operation of the installations under quasi-steady conditions do not allow but rarely the performance of more delicate manoeuvres, which diminishes the experience of the operators in the control rooms.

- an increased automation diminishes in its turn the operators' experience, as the needs for personnel training grow
- the personnel training in the conventional manner, at the workplace and on the operating equipment) is expensive, poorly productive and does not cover all the possible situations, so much the less as the specific incident/failure states
- the possibility of developing exercise, both for beginners and advanced, of a large number of operating states without the risk to destroy the extremely expensive installations

- one can analyse and experiment, in laboratory, the modalities of improving the operation of technological installations
- one can ensure a good training of the newly employed personnel
- one can check the training level of the existing personnel
- under the current conditions, due to the low electric power consumption, there are long periods when the power units stop. The need to train

continuously the operators increases, as it is once more necessary to ensure the maintenance of a high level of personnel training

- improving the knowledge on the power equipment operation leads to an increase in the operating efficiency, to a lower number of interruptions due to incidents and failures, as well as to the reduction in reparation costs due to incidents and failures.

## References:

1. LĂZĂROIU Gh., *Modelling and simulink program systems*, POLITEHNICA PRESS, Bucharest, 2005.
2. LĂZĂROIU Gh., *Dynamic modelling and simulation of power station*, Printech, I Bucharest 1998.
3. F. Gagliardi, M. Roscia, Gh. LAZAROIU, *Evaluation Of Sustainability Of A City Through Fuzzy Logic*, ENERGY 32 (2007), pp.795-802.