

COULD SUSTAINABLE ENERGY TECHNOLOGY HELP OVERCOMING CRISIS? CASE STUDY: INSTALLATION OF A COGENERATION UNIT WITHIN A CHEMICAL COMPANY

VORONCA. M.-M.* , VORONCA S.-L.** , CRUCERU M.”**

*Romanian Energy Efficiency Fund, Johann Strauss no. 2A, Bucharest,

**C.N.T.E.E. Transelectrica S.A., Olteni no. 2 - 4, Bucharest

University “Constantin Brâncuși” Târgu Jiu, Republicii no. 1, Târgu Jiu
mihai.voronca@free.org.ro

Abstract - *Despite the fact that crisis affected Romania later than other EU Member States, local exporting companies on the unique market faced their turnover decrease even before the recession affected the country. To limit the damages, several investors decided to cut costs by redirecting their actions towards using sustainable energy technologies. This paper presents the relevant case of an important local chemical company, whose executive management decided to implement a sustainable energy-based technological investment with the unique purpose of modernising energy use.*

Keywords: sustainable energy technology, crisis, investment, performances, monitoring.

1. INTRODUCTION

Chimcomplex S.A. Borzești is a most important Romanian chemical products manufacturer and supplier, with a great experience of operating for more than 50 years. Chimcomplex S.A. Borzești, now under new leadership, has been founded in 1954 and privatised in 2003.

The main activity of the company consists in manufacturing and commercializing of organic and synthesis products, chlorine products and pesticides. From a total of 45 final products currently manufactured, the company is supplying the market with 20 final products as a unique producer, the exportation representing about 72% (in 2006) in total sales.

Several economic sectors are supplied with the company products: agriculture, power generation, chemical and petrochemical industry, pulp and paper, pharmaceutical industry, metallurgy, food industry, rubber and plastics etc.

The Romanian Ministry of Public Finances website (<http://www.mfinante.ro>) indicates that the company's turnover was US\$49.86million in 2005, US\$63.13million in 2006, US\$70.97million in 2007 and US\$64.90million in 2008.

Relevant for the purpose of the present paper is that the turnover for 2006 - 2008 remained almost in the same range.

As found on the Romanian Energy Efficiency Fund website (<http://www.free.org.ro>), in 2006, the total annual natural gas consumption was of 19,219,000 Nm³/year and the total annual power consumption was of 333,209 MWh/year. For the average prices (VAT excluded) of electricity (64 US\$/MWh) and natural gas (277 US\$/1000Nm³), the annual energy bill totalled US\$26.5million/year, which represented about 33% of annual manufacturing costs and about 46% of company's overall annual operation costs.

Despite the lack of relevant information, it is presumably acceptable that such high annual energy expenditures have determined the executive board to invest in sustainable energy technologies, towards maximising the company's profit.

After examining several best available technologies (BAT), the executive board has decided to install a “gas turbine with heat recovery”, a continuously operating cogeneration unit running on natural gas. Consequently, at the beginning of 2007, an investigation of the specialised market in order to meet the financing requirements determined the executive board to begin negotiations with the Romanian Energy Efficiency Fund [7], which promptly awarded Chimcomplex SA with a US\$2.00million loan, while the rest were to be financed from company's own capital.

The purpose of this paper is to present the results and conclusions of a generally recognised methodology based investigation [1], on how investing in sustainable energy technologies could help companies in managing their business as usual, in spite of a possible precarious financial situation.

2. METHODOLOGY

In line with the provisions of Annex III of the Directive 2004/8/EC on the promotion of cogeneration-based solutions on a useful heat demand in the internal energy market [1], the amount of primary energy savings provided by cogeneration

production will be calculated with the formula:

$$PES = \left(1 - \frac{1}{\frac{CHP H\eta}{Ref H\eta} + \frac{CHP E\eta}{Ref E\eta}} \right) \times 100\% , (1)$$

where:

- PES - the primary energy savings;
- CHP H η - the heat efficiency of the cogeneration production, defined as an annual useful heat output divided by the fuel input used to produce the sum of useful heat output and electricity from cogeneration;
- REF H η - the efficiency reference value for separate heat production;
- CHP E η - the electrical efficiency of the cogeneration production defined as annual electricity from cogeneration divided by the fuel input used to produce the sum of useful heat output and electricity from cogeneration;
- REF E η - the efficiency reference value for separate electricity production.

The justification for using this particular method consists of the fact that the "gas turbine with heat recovery" is listed in the Annex I of the Directive 2004/8/EC [1]. Better yet, such sustainable energy technology may be regarded as high-efficiency cogeneration as indicated in the Annex III of the Directive 2004/8/EC [1], if the production from cogeneration units provides primary energy savings calculated as previously indicated of at least 10% compared to the references for separate production of heat and electricity.

Synthetically, the purposes of using the current method consist of promptly delivering valid data referring to an existing situation analysing the efficiency of the separate production of heat and electricity, while collecting accurate information regarding the efficiency of an alternative sustainable energy technology. This might be the reason for which the following chapter contains the analysis of heat and power production and generation efficiency throughout the relevant year 2006, along with detailed investigation of the further sustainable energy-efficient technology based on cogeneration production.

3. PROJECT HIGHLIGHTS

3.1. Presentation of the initial energy situation in the relevant year 2006

The analysis of the initial energy generation and production of Chimcomplex S.A. Borzești in 2006 revealed that the company operated through a plant consisting of 3 steam boilers, mainly fuelled by natural gas and, additionally, on hydrogen resulted from electrolysis, a well-known high electricity consuming process. The technical characteristics of the existing boilers are: the 10 Gcal/h natural gas

fired boiler can generate an amount of 15 t/h overheated steam (15 bar, 240°C), the 6 Gcal/h natural gas and hydrogen fired boiler has a capacity of 10 t/h (15 bar, 270°C), and the 6 Gcal/h natural gas fired boiler steam production is 10 t/h(15 bar, 270°C). In 2005, the executive board hired a specialised company to audit the existing heat plant. The certified results showed that the overall gross efficiency of the heat plant should be considered of 94.31% against a net efficiency of 82.82%. This value is to be associated to the variable REF H η from the formula (1).

Due to the technological processes within the factory, Chimcomplex S.A. is an important electricity end user, as presented in chapter 1. To cover the demand, the company, which is an eligible customer, buys electricity directly from local energy suppliers (in line with the definitions from Directive 2003/54/EC [2], 'eligible customers' means customers who are free to purchase electricity from the supplier of their choice).

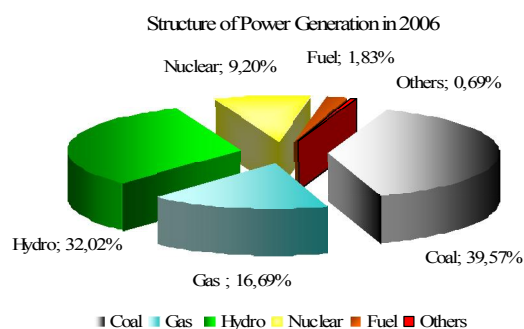

Fig. 1. The power generated and delivered to the grid in 2006 (<http://www.anre.ro>)

In 2006, the electricity market was dominated by fossil fuel-based electricity producers (Fig.1.). Following the official data gathered from the website of the National Regulatory Body for Electricity (<http://www.anre.ro>) the annual total amount of electricity generated and delivered to the grid was about 58.09%, while being obtained from the usage of fossil fuel [3]. Authors consider this issue relevant for the present paper for at least two reasons. First, on a 100% deregulated electricity market, there is a tough competition among suppliers. Secondly, with less than 10% nuclear based electricity production and with only a small contribution of hydro-based electricity production (as this kind of electricity is the subject of long-term commercial purchasing arrangements), suppliers are obliged to purchase the remaining fossil fuel-based electricity production. If cogeneration-based electricity generation is excluded and only the condensation-based electricity production used, it is possible that a large ratio of the annual total amount of electricity supplied to Chimcomplex S.A. might be fossil fuel-based.

The Order of the Minister of Environment and Water Management No. 85 from 26 January 2007 approving the Methodology for the elaboration of the National Allocation Plan [4], stipulates that the efficiency reference value for separate electricity

production in thermal power plants in Romania is 31.85% (based on 2004 data reported by the Romanian National Institute for Statistics to several international organisations as International Energy Agency, Eurostat and United Nations Economic Commission for Europe). This value is to be associated to the variable REF $E\eta$ from the formula (1).

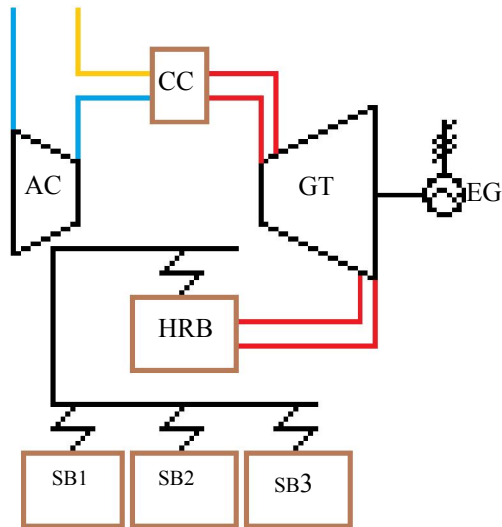

Fig. 2. The cogeneration plant sketch: AC-Air Compressor; CC-Combustion Chamber; GT-Gas Turbine; EG-Electric Generator; HRB-Heat Recovery Boiler; SB_{1,2,3}-Existing Steam Boilers.

3.2. Presentation of the sustainable energy technology performances

With the main concern of cutting costs through modernising energy use, the company's Board has decided to install a new and highly-efficient cogeneration facility consisting in a gas turbine and generator, with a heat recovery post combustion boiler connected to the common header of the existing boilers from the heat plant (fig.2). Based on the conclusions of the Feasibility Study performed by the Institute for Studies and Power Engineering (ISPE), the equipment manufacturer Turbomach (Switzerland) supplied the company a cogeneration unit with a power to heat ratio of 0.5688, respectively a gas turbine based power generation rated capacity of 7.5 MW_e (fig.3), and a heat generation rated capacity of 13.2 MW_t. Following supplier's prescriptions, to reach this power level, inside the gas turbine combustion chamber a natural gas ISO hourly quantity of 2.8 t/h (i.e. 2,550 Nm³/h) is to be consumed. The guaranteed electrical efficiency of the cogeneration production is 31.9%, value which should be associated to the variable CHP $E\eta$ from the formula (1).

The heat recovery post combustion boiler can generate a maximum overheated steam mass rate of 29 t/h (16 bar, 240°C), implying a natural gas ISO hourly consumption of 0.9 t/h (i.e. 910 Nm³/h). The guaranteed heat efficiency of the cogeneration

production is 55.0%, value which should be associated to the variable CHP $H\eta$ from the formula (1).

Based on previous information, the cogeneration unit has to account for a guaranteed average overall efficiency of 86% (greater than the minimum limit of 80% imposed by the Annex II of the Directive 2004/8/EC [1], for gas turbine with heat recovery based cogeneration facilities), and is required to operate 8,400 hours/year.

The new co-generation unit will be equipped with axial compressor, gas turbine, fuel system, lubrication system and automation system of control command. The modular structure and the containerized shape will allow a flexible operation and the installation in a perimeter near of the existing heat plant.

3.3. Estimated Primary Energy Savings

Based on the methodology from Annex III of the Directive 2004/8/EC [1], the estimated primary energy savings PES of the cogeneration unit are:

$$PES = \left(1 - \frac{1}{\frac{55.00}{82.82} + \frac{31.90}{31.85}} \right) \times 100\% = 39.2\% \quad (2)$$

The above value of PES qualifies the company's cogeneration facility as high-efficient cogeneration, as in the Annex III is stipulated that the "cogeneration production from cogeneration units shall provide primary energy savings calculated according to point (b) of at least 10 % compared with the references for separate production of heat and electricity".



Fig. 3. Natural gas fired cogeneration unit: the gas turbine (<http://www.free.org.ro>)

For absolute energy savings values calculation purposes, it should be assumed that both annual amount of heat and electricity from cogeneration are to be considered as separate types of generation, where, on one hand, the heat is produced within existing heat plant with the efficiency indicated in paragraph 3.1., and on the other hand, the power is generated in thermal power plants with the efficiency mentioned in [4].

The calculation of the annual amount of heat from cogeneration is based on a hourly saturated steam consumption of 20 tones/hour from a maximum 29 tones/hour (representing a cogeneration unit average annual thermal load of 69%) with the pressure 16 bar, the saturation temperature 201.36°C and the related enthalpy 2,793kJ/kg.

The resulting cogeneration instant heat amount is:

$$Q_{\text{CHP}} = m \times \Delta h_{\text{CHP}} = \frac{20,000 \text{ kg}}{3,600 \text{ s}} \times 2,373.32 \frac{\text{kJ}}{\text{kg}}, \quad (3)$$

$$Q_{\text{CHP}} = 13.19 \text{ MW}_t$$

where:

Q_{CHP} - the instant heat amount of the cogeneration unit;

m - the annual amount of saturated steam from the heat recovery boiler;

Δh_{CHP} - the enthalpy increase in the heat recovery boiler (flue gases – water heat exchange).

Based on the value of the instant heat amount from relations (3), the annual amount of heat from cogeneration is:

$$H_{\text{CHP}} = Q_{\text{CHP}} \times \tau_{\text{CHP}} = 13.19 \text{ MW}_t \times 8,400 \frac{\text{hours}}{\text{year}}, \quad (4)$$

$$H_{\text{CHP}} = 110,755 \frac{\text{MW}_t \text{h}}{\text{year}}$$

where,

H_{CHP} - the annual amount of heat from cogeneration;

τ_{CHP} - the cogeneration annual operation period.

The calculation of the annual amount of electricity from cogeneration considers the 100% load of the cogeneration power capacity during the whole operation period:

$$E_{\text{CHP}} = P_{\text{CHP}} \times \tau_{\text{CHP}} = 7.5 \text{ MW}_e \times 8,400 \frac{\text{hours}}{\text{year}}, \quad (5)$$

$$E_{\text{CHP}} = 63,000 \frac{\text{MW}_e \text{h}}{\text{year}}$$

where,

E_{CHP} - the annual amount of electricity from cogeneration;

P_{CHP} - cogeneration power capacity of the cogeneration unit;

Considering the heat efficiency of the cogeneration production CHP $H\eta$ of 55.0% as indicated in the paragraph 3.2., the total annual amount of primary energy consumption PEC_{CHP} of the cogeneration unit is:

$$\text{PEC}_{\text{CHP}} = \frac{H_{\text{CHP}}}{\text{CHP } H\mu} = \frac{110,775 \text{ MW}_t \text{h}}{55.0\%}, \quad (6)$$

$$\text{PEC}_{\text{CHP}} = 201,499 \frac{\text{MW}_{\text{PE}} \text{h}}{\text{year}}$$

If the considered natural gas caloric value CV_{NG} is 9.37 $\text{kW}_{\text{PE}}\text{h}/\text{m}^3$, as indicated in the Feasibility Study, the total annual amount of natural gas consumption for cogeneration is:

$$\text{NGC}_{\text{CHP}} = \frac{\text{PEC}_{\text{CHP}}}{\text{CV}_{\text{NG}}} = \frac{201,499 \text{ MW}_{\text{PE}} \text{h}/\text{year}}{9.37 \text{ kW}_{\text{PE}}\text{h}/\text{Nm}^3}, \quad (7)$$

$$\text{NGC}_{\text{CHP}} = 21,504,000 \frac{\text{Nm}^3}{\text{year}}$$

In the case of separate heat and electricity production, the information given in the paragraph 3.1. is to be used. Consequently, the annual amount of natural gas consumption for separate heat production NGC_{REFH} is:

$$\text{NGC}_{\text{REFH}} = \frac{H_{\text{CHP}}}{\text{REF } H\eta \times \text{CV}_{\text{NG}}} = \frac{110,755 \text{ MW}_t \text{h}/\text{year}}{0.8282 \times 9.37 \text{ kW}_{\text{PE}}\text{h}/\text{Nm}^3}; \quad (8)$$

$$\text{NGC}_{\text{REFH}} = 14,271,669 \frac{\text{Nm}^3}{\text{year}}$$

The annual amount of natural gas consumption for separate electricity production NGC_{REFE} is:

$$\text{NGC}_{\text{REFE}} = \frac{E_{\text{CHP}}}{\text{REF } E\eta \times \text{CV}_{\text{NG}}} = \frac{63,000 \text{ MW}_e \text{h}/\text{year}}{0.3185 \times 9.37 \text{ kW}_{\text{PE}}\text{h}/\text{Nm}^3}; \quad (9)$$

$$\text{NGC}_{\text{REFE}} = 21,109,504 \frac{\text{Nm}^3}{\text{year}}$$

From relations (8) and (9) it results the annual amount of natural gas consumption for separate heat and electricity production which is:

$$\text{NGC}_{\text{SEPARATE}} = \text{NGC}_{\text{REFH}} + \text{NGC}_{\text{REFE}} = 35,381,174 \frac{\text{Nm}^3}{\text{year}}. \quad (10)$$

Using absolute values determined with relations (7) and (10) the annual amount of natural gas savings is:

$$\text{NGC}_{\text{SAVINGS}} = \text{NGC}_{\text{SEPARATE}} - \text{NGC}_{\text{CHP}} = 13,877,174 \frac{\text{Nm}^3}{\text{year}}, \quad (11)$$

or in relative values:

$$\text{PES} = \frac{\text{NGC}_{\text{SAVINGS}}}{\text{NGC}_{\text{SEPARATE}}} = \frac{13,877,174 \frac{\text{Nm}^3}{\text{year}}}{35,381,174 \frac{\text{Nm}^3}{\text{year}}} \times 100\% \quad (12)$$

$$\text{PES} = 39.22\%$$

In conclusion, for the values of efficiency already considered, the separate production of the annual heat amount of 110,775 $\text{MW}_t\text{h}/\text{year}$ and the annual electricity amount 63,000 $\text{MW}_e\text{h}/\text{year}$ is possible if a total annual amount of natural gas of 35,381,174 Nm^3/year is consumed. Alternatively, the production of the same annual heat and electricity amounts in cogeneration is possible with a total annual amount of natural gas of 21,504,000 Nm^3/year .

3.3. Adequate Financial Perspectives

As found on the Romanian Energy Efficiency Fund website, in 2006, the total annual natural gas consumption was of 19,219,000 Nm^3/year (i.e. the equivalent of US\$5.32million/year for a natural gas price of 277 US\$/1000 Nm^3 , VAT excluded).

For cogeneration production of heat and power, the corresponding total annual natural gas consumption is estimated at 21,504,000 Nm^3/year (i.e. the equivalent of US\$5.96million/year for a

natural gas price of 277 US\$/1000Nm³, VAT excluded), which represents a less attractive increase of the total annual natural gas bill of 12%, compared to the separate production. But the attractiveness of the sustainable energy technology solutions rises from the amplitude of the avoided costs which represents “the capital and expense that would have to be spent if the project did not proceed” (<http://financial-dictionary.thefreedictionary.com>). More precisely, the production of electricity in cogeneration shall eliminate the purchase of 63,000 MW_eh/year (i.e. the equivalent of US\$4.03million/year for a price of electricity amounting to 64 US\$/MW_eh, VAT excluded).

Finally, the estimated annual financial benefits of production in cogeneration compared with the separate production are amounting to US\$2.03million/year.

3.4. Favourable Environmental Impact

The use of this type of sustainable energy technology shall significantly improve the environmental impact of the energy generation through the intensive manner of fuel use, both locally and nationally wide. Main outcomes of the project are:

- the equivalent fuel savings of 11,181 toe_{TPEs}/year (in line with the provision of the Directive 2004/8/CE) and the resulting financial benefits of US\$2.03million/year implementation are significantly important;
- decrease of equivalent fuel consumption (in line with the provision of the Directive 2004/8/CE) will lead to significant reduction of CO₂ emissions; based on the records published by the International Energy Agency in 2009 [5], specifying that one toe_{TPEs} in Romania would emit 2.36 tonnes of CO₂, it results that the avoided emissions of CO₂ amounts at 26,387 tonnes CO₂/year.

All provided information is given authors with much enough reasons to affirm that sustainable energy technologies are greening the environment.

3.5. Total Investment Size

Following the estimations of the Feasibility Study, the total investment size was expected to come to US\$8.147million (Table 1).

Project	US\$
Gas turbine with the electrical ISO rated power of 7.5 MW _e (including auxiliary equipments, design, transport, erection works etc.)	4,000,000
Heat recovery post combustion boiler with the rated capacity of 20 t/h, 15 bar, 240°C (including auxiliary equipments, design, transportation, erection works etc.)	3,000,000
Execution of connections to the existing installations (design, transport, erection works, systems of inlet supply with natural gas and water, system of outlet supply with overheated steam, power etc.)	1,147,000
Total	8,147,000

Costs in Table 1 do not include expenditures with electric, natural gas and hydrogen networks. Costs include custom duties, storage taxes and transportation fees and do not include VAT.

Compared with estimated annual financial benefits of US\$2.029million/year, this investment amounting to US\$8.147million wasn't considered too costly for a company reporting turnovers of several dozen of million of US dollar. More than that, the board was committed in using, if needed so, the company's own cash to entirely fill up the financing gap.

4. RESULTS AND DISCUSSIONS

4.1. The Crisis: First Signs

After being comforted with the excellent results of the Feasibility Study performed by ISPE and keeping the cap towards significantly modernising the energy use and to consistently cutting the annual energy expenditures, the executive board of Chimcomplex decided to invest into sustainable energy technologies towards maximising the company's profit.

Consequently, at the beginning of 2007, investigations on the specialised market, in order to cover the financing requirements have been initiated.

Traditionally, companies can apply to their home banks which have the advantage of the availability of the already gathered data regarding the applicants' creditworthiness.

In normal market conditions, if the indebtedness rate is not too high (usually home banks cover clients' working capital needs) and the liquidity of proposed collaterals is fair enough, clients might have the chance to be awarded with the necessary capital for investment.

In June 2007, rumours about the international financial crisis (with apparent causes determined by the increase of governing interest rates decided in early 2006 by the Federal Reserve [11]) were transformed into dramatically bad news, the American banking sector being the first affected (in only three days, the American investment bank Bear Stearns faced liquidity losses amounting to US\$17million). But the local financial market weakly connected to the American market remained stable.

In this context, did they the local bankers understand the advantages of using sustainable energy technologies towards the company's profit maximisation, and consequently accept to finance Chimcomplex Borzești facing the investment related performances? How the investment performances looked like? The classic indicators are presented.

4.2. Investment Performance Indicators

The ratio noted with R, between the discounted annual revenues and the discounted annual expenditures, represents, after [6], the annual revenues obtained after a financial effort and

expressed in the same currency the investment and operation is related to.

The relation is:

$$R = \frac{\sum V_h \frac{1}{(1+a)^h}}{\sum (I_h + C_h) \frac{1}{(1+a)^h}} > 1, h = \overline{1, D+d} \quad (13)$$

where,

- a - the discount rate;
- h - the year of expenditure or earning;
- d - the duration of erection works;
- D - the lifetime of investment;
- V_h - the annual revenue in year h;
- C_h - the annual expenditure in year h;
- I_h - the annual investment in year h.

The discounted cash flow CF_h depicts the annual situation of revenues and expenditures for every year from the interval 1, d+D:

$$CF_h = [V_h - (I_h + C_h)] \frac{1}{(1+a)^h}, h = \overline{1, D+d} \quad (14)$$

During the first years from the interval 1, d+D, especially during the period d of investment execution, expenditures exceed revenues and the discounted cash flow CF_h takes negative values. In the following period of results consolidation, the profit is greater and the discounted cash flow CF_h becomes strongly positive [9].

During the last period, expenditures rise against the revenues decrease, due to the exit from the guarantee period and to the overall performances decrease of installations and equipments [6].

The net present value NPV designates the net discounted revenues over the entire period of time 1, d+D [6]. The relation is:

$$NPV = \sum CF_h > 0, h = \overline{1, D+d} \quad (15)$$

The net present value can be also determined, as indicated in [6], through the summing of all discounted cash flows over the whole period of 1, d+D:

$$NPV = \sum_{h=1}^{d+D} \frac{V_h}{(1+a)^h} - \sum_{h=1}^{d+D} \frac{I_h + C_h}{(1+a)^h} > 0 \quad (16)$$

The internal rate of return IRR indicates the economic strength of the further industrial unit and designates that value of the discount rate for which the net present value NPV becomes null ($NPV=0$). After [6], the IRR can be analytically obtained using the relation (17):

$$IRR = a_{min} + (a_{max} - a_{min}) \frac{NPV_+}{NPV_+ + |NPV_-|} \quad (17)$$

or graphically [6], as suggested in fig. 4.

Successive attempts are to be performed for both coefficients a_{min} and a_{max} determination. In reference [6] is recommended that the difference between coefficient values should remain under 5%, but the correspondent NPVs to get one positive value and the other a negative value.

The gross payback time GPT designates the period after which, through the cash flow released by investment operation, the total size of investment was entirely paid back [6]. The relation is the following:

$$\sum_{h=1}^{GPT} [V_h - (I_h + C_h)] = 0 \quad (18)$$

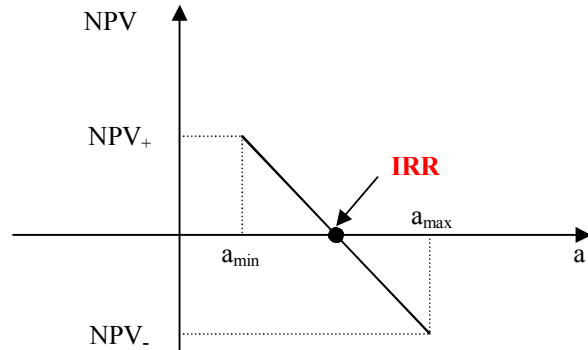

Fig. 4. Graphic determination of the internal rate of return (source: Malamatenios, Ch., Vezirigianni, G., Grepmeier, K., Renewable Energies & Energy Efficiency: training guidebook, NicVox Publishing House, ISBN (13) 978-973-8489-37-0, București, 2007).

If the annual cash flows have uniform values, the gross payback time is to be determined with the relation:

$$GPT = \frac{I}{V - C} \quad (19)$$

The determination of the gross payback time is based on the exact definition of the zero time moment, which is normally associated to the investment commissioning.

The discounted payback time DPT [6], designates the period after which through the discounted cash flow released by investment operation, the total size of investment was entirely paid back. Additionally, a discounted cash flow determined based on the value of the discount rate can be obtained, too. The relation for the calculation of the discounted payback time is:

$$\sum_{h=1}^{DPT} \frac{V_h - (I_h + C_h)}{(1+a)^h} = 0 \quad (20)$$

If the annual cash flows have uniform values, the discounted payback time can be obtained after [6], by using the gross payback time is to be determined with the relation:

$$DPT = - \frac{\ln(1 - GPT * a)}{\ln(1 + a)} \quad (21)$$

The determination of the discounted payback time is also based on the exact definition of the zero time moment, which is normally associated to the investment commissioning.

4.3. Performance Indicators Values

The values associated to the investment performance indicators were used by the executive board of Chimcomplex Borzești in quantifying further chances to meet expectations after the project implementation.

The modernization of energy use within the

company and the improvement of the financial situation through costs cutting were the previously mentioned priorities.

For confidentiality reasons, the authors have decided to present credible enough values, based on input data slightly different from the initial ones. The following simplified input data were considered as relevant:

- the discount rate is $a = 12\%$, greater than the value of 8% recommended in the banking sector or 5% used when accessing Structural Instruments; the chose value contributes to a more pessimistic financial perspective than the other smaller values;
- the duration of erection works is $d = 1$ year;
- the lifetime of investment is $D = 10$ years;
- the amount of net revenues is $V_h = 2.029$ millions of US dollars a year; the amount of annual revenues is constant;
- the amount of annual expenditure is $C_h = 0$;
- the investment during the year d is $I_h = 8.147$ millions of US dollars; for any other year h from the interval $d, D + d$ is null.

Under such premises, a worksheet in MS Excel has been created. The output data are presented in Table 2.

Table 2

Investment Performance Indicators	Year $h = 1, D + d$					
	$d = 0$	$h = 1$	$h = 2$	$h = 3$	$h = 4$	$h = 5$
	kUS\$	kUS\$	kUS\$	kUS\$	kUS\$	kUS\$
I_h	-8,147	0	0	0	0	0
V_h	0	2,029	2,029	2,029	2,029	2,029
C_h	0	0	0	0	0	0
$V_h - (I_h + C_h)$	-8,147	-6,118	-4,090	-2,061	-32	1,996
$1/(1 + a)^h$	1.00	0.89	0.80	0.71	0.64	0.57
CF_h	-8,147	-6,336	-4,718	-3,275	-1,985	-834
a	12%					

Table 2 (continuation)

Investment Performance Indicators	Year $h = 1, D + d$					
	$d = 0$	$h = 6$	$h = 7$	$h = 8$	$h = 9$	$h = 10$
	kUS\$	kUS\$	kUS\$	kUS\$	kUS\$	kUS\$
I_h	-8,147	0	0	0	0	0
V_h	0	2,029	2,029	2,029	2,029	2,029
C_h	0	0	0	0	0	0
$V_h - (I_h + C_h)$	-8,147	4,025	6,054	8,082	10,111	12,139
$1/(1 + a)^h$	1.00	0.51	0.45	0.40	0.36	0.32
CF_h	-8,147	194	1,111	1,931	2,662	3,315
a	12%					
GPT	4.015	years				
DPT	5.8	years				
NPV	3,315	kUS\$				
IRR	21%					

Based on data from table 2, the values of the investment performance indicators are established. The value of R (necessarily greater than 1), is:

$$R = \frac{\sum_{h=1}^{D+d} V_h \frac{1}{(1+a)^h}}{\sum_{h=1}^{D+d} \frac{(I_h + C_h)}{(1+a)^h}} = \frac{US\$30,105,000}{US\$8,147,000} = 3.70 > 1, (22)$$

value which favourably denotes that the annual revenues obtained after the financial effort is 3.70 times greater than the annual investment and operation.

The net present value NPV (necessarily greater than 0) is:

$$NPV = \sum_{h=1}^{d+D} \frac{V_h - (I_h + C_h)}{(1+a)^h} = US\$3,315,000 > 0, (23)$$

value which shows that the net discounted revenues over the lifetime of investment is strongly positive. After performing successive attempts for coefficients a_{min} and a_{max} determination, the internal rate of return IRR gets the value:

$$\begin{aligned} IRR &= a_{min} + (a_{max} - a_{min}) \frac{NPV_+}{NPV_+ + |NPV_-|} = \\ &= 21.28\% + (21.29\% - 21.28\%) \frac{1}{1 + |-1|} =, (24) \\ &= 21.285\% \end{aligned}$$

which proves a good economic strength of the further industrial unit as long as this value is greater than the discount rate = 12% used for the cash flow projection. Graphically, notations from figure 4 get values as follows:

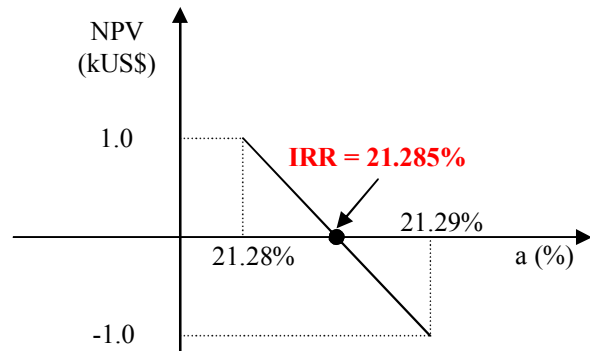

Fig. 5. Graphic determination of the internal rate of return for the sustainable energy technology investment in Chimcomplex Borzești

and the internal rate of return receives the same value as previously. It is important to mention that formula IRR() from MS Excel returns the same value 21.285%.

The gross payback time GPT is:

$$GPT = \frac{I}{V - C} = \frac{US\$8,147,000}{US\$2,029,000} = 4.015 \text{ years}, (25)$$

this indicates that in 4 years, the total size of investment should be entirely paid back. For comparison reasons, investments in power sector are usually paid back in periods of time which exceed 10 years, with a special mention for the nuclear power sector in which periods are close to the capacities lifetime, i.e. more than 20 years.

The discounted payback time DPT is:

$$\begin{aligned} DPT &= - \frac{\ln(1 - GPT * a)}{\ln(1 + a)} = \\ &= - \frac{\ln(1 - 4.015 * 12\%)}{\ln(1 + 12\%)} = 5.80 \text{ years} \end{aligned} \quad (26)$$

As it has been previously showed, the values associated to the investment performance indicators are quite good looking and they have comforted the executive board of Chimcomplex Borzești that the decision to invest in sustainable energy technology was adequate.

4.4. Financing: Decision to Lend

Facing such favourable perspectives after the project implementation, the executive board of the

company started, early 2007, to contact different banking institutions located in their geographical area for commercial lending offers [8]. It would be credible that simultaneously, the board entered in preliminary discussions with the Romanian Energy Efficiency Fund in order to get a commercial lending offer [10], too. No information about the results of negotiations with banks was obtained but certainly, the results of discussions with the Fund were favourable. And it isn't too difficult to understand why the Fund's reacted so: the perspectives of being involved into a energy use modernisation implying a sustainable energy technology. After intense negotiations with the executive board, the Romanian Energy Efficiency Fund has promptly awarded Chimcomplex SA with a US\$2.00million loan, while the rest were to be financed from company's own capital. The maturity of the awarded loan was established at 5 years and the grace period at 12 months, the collaterals [8], provided by the company being: (i) pledge final products stocks; (ii) pledge on equipments purchased within the energy efficiency cogeneration based project; (iii) promissory notes. Repayments are to be made in equal quarterly based rates. It seems the financing agreement signed in May 2007, provided enough comfort for company to start negotiations with equipment manufacturer in order to find the best financial offer.

4.5. Crisis Enhancement: Walk on Wire

The vigorous phase of crisis hit the international market of chemical products in 2008. Despite these less attractive international perspectives, the executive board strategically decided to mobilize all available capital (cash) to finalize the project implementation. This risky decision has allowed the selected manufacturer to deliver equipments and to start all needed erection works. The commissioning of the new natural gas fuelled co-generation facility, initially due for the first quarter 2009, was done mid-March same year.

End of 2008 and beginning of 2009, due to the company's exposure to export activities, troubles started to affect its financial stability. Under such circumstances, the energy use within different production departments within the company faces a gradual diminishment, only the internal market being the reason of relative financial stability. In 2009 the crisis hits Romania and the company felt effects without any doubt. Against an amount of US\$64.90million in 2008, in 2009, the turnover was of only US\$31.43, as indicated by the official records of the Romanian Ministry of Public Finances. In mid-2009, the executive board started to look for an emergency exit, the solution being a postponement of debt service deadlines. Being supplied with very first preliminary results of cogeneration unit operation in terms of efficiency and energy savings, and recognising the very professional market - oriented attitude of the executive board, the Romanian Energy Efficiency Fund has taken the favourable decision, transferring a part of the risk exposure from the

company to itself. Beginning of 2010 represented the activities reply on the international market, the company step by step gaining its financial stability.

4.5. Monitoring and Evaluation

It was previously mentioned that the cogeneration unit in Chimcomplex Borzești will operate to cover the annual total heat demand and only a part of the annual electricity demand of the company. No electricity export on the internal electricity market will occur, cause for which the company will probably never apply for the bonus - compulsory quota based financial support system in place in the country for cogeneration stimulation as required by the Directive 2004/8/EC.

The cogeneration unit is fully equipped, automation and online data transmission systems are put in place, and the monitoring of the cogeneration unit is as easy as complete.

Data collected during the preliminary tests of heat and power generation conducted immediately after the unit commissioning have confirmed the expectations of the executive board in terms of modernisation of energy use and efficiency increase. Evaluations issued by the equipment manufacturer have revealed even greater values then initially estimated. Years 2009 and 2010 results have been better.

5. CONCLUSIONS

Sustainable energy technology has to deal with the national energy policy priorities, as the Romanian electricity market still remains dominated by fossil fuel-based production and supply. In line with EU state aid rules, the existing financial support scheme might be extended to several technologies, other than cogeneration.

Sustainable energy technology implies existing and certain energy consumption. Savings obtained through the entire cut of energy consumption should be considered quite similar with a black-out, that's an unusual situation.

Sustainable energy technology deals with the modernisation of energy use. The modernisation process could be considered more effective if energy savings are obtained, rather than a decrease of energy intensity. The process might be incentivised by implementing a system of energy savings certificates, imposing quotas for energy suppliers and awarding bonuses for economic operators implementing energy efficiency investments.

Sustainable energy technology could help companies to improve the cash flow. As described, adequate management decisions to limit the disastrous crisis effects might imply investments in such technologies.

Sustainable energy technology requirements are (i) a well defined energy use demand to cover, (ii) an appropriate connection with that part of energy demand which is almost time - invariant (iii)

appropriate risk management and (iv) rigorous financial discipline when the business is jeopardised.

REFERENCES

- [1]. *** Directive 2004/8/EC of the European Parliament and the Council on 11 February 2004 on the promotion of cogeneration based on a useful heat demand in the internal energy market and amending Directive 92/42/EEC, Official Journal of the European Union L52, 2004, pp. 50 - 60.
- [2]. *** Directive 2003/54/EC of the European Parliament and of the Council of 26 June 2003 concerning common rules for the internal market in electricity and repealing Directive 96/92/EC, Official Journal of the European Union L176, 15.07.2003, 2003, pp. 37 - 53.
- [3]. *** Government Decision No.1069 from 05 September 2007 approving the Romanian Energy Strategy for the period 2007 - 2020, Official Monitor of Romania, Part I, Year XIX - No.781, 19.XI.2007, pp. 2 - 48.
- [4]. *** Order of the Minister of Environment and Water Management No. 85 from 26 January 2007 approving the Methodology for the elaboration of the National Allocation Plan, Ministry of Environment and Water Management, Official Monitor of Romania, Part I, Year XIX - No.101, 09.II.2007, pp. 8 - 36.
- [5]. *** Key World Energy Statistics 2009, OECD/IEA, International Energy Agency, 9, rue de la Federation, 75739 Paris Cedex 15, www.iea.org, 2009.
- [6]. M.-M. Voronca (coordinator), T. Constantinescu, M. Cruceru, A.M. Fodi, A. Marin and S.L. Voronca, FINANȚAREA INVESTIȚIILOR ÎN EFICIENȚĂ ENERGETICĂ, Editura AGIR, București, ISBN 973 - 720 - 200 - 0, 2008.
- [7]. I.S. Lefter, M.-M. Voronca and M. Cruceru, 'Finanțarea comercială a investițiilor pentru utilizarea rațională a energiei și valorificarea surselor regenerabile de energie: studii de caz', EMERG Energie • Mediu • Economie • Resurse • Globalizare, Volumul IV, ISBN 978-973-720-137-9, Editura AGIR, București, 2008, pp. 35 - 60.
- [8]. A. Leca and V. Mușatescu (coordinators), M.-M. Voronca & all, MANAGEMENTUL ENERGIEI •PRINCIPII, CONCEPTE, POLITICI, INSTRUMENTE•, Academia de Științe Tehnice din România, Editura AGIR, București, ISBN 973 - 720 - 087 - X, 978 - 973 - 720 - 087 - 7, 2007.
- [9]. M.-M. Voronca, R. Dumitrescu, A.M. Fodi and A. Marin, 'Investment portfolio and portfolio investment for a sustainable development', Scientific Bulletin, Series C: Electrical Engineering, Volume 69, 2007, Number 4, University POLITEHNICA of Bucharest, ISSN: 1454-234x, Editura Politehnica Press, pp. 173 - 180, 2007.
- [10]. I.S. Lefter, M.-M. Voronca and M. Cruceru, 'RUE and RES Commercial Financing: A Case Study', Mesagerul Energetic, Buletin informativ al Comitetului Național Român al Consiliului Mondial al Energiei, Anul VII, Nr. 74, Decembrie 2007, București, 2007, pp. 11 - 14.
- [11]. A. Bal, Opinii privind cauzele crizei financiare actuale, The Romanian Economic Journal, Year XII, no. 31, 2009, pp. 3 - 18.