

# CONSIDERATION ABOUT SYMMETRIC COMPONENTS CIRCULATION IN THREE-PHASE SYSTEMS

MATICA, L.M.\*

\*University of Oradea, Faculty of Electrical Engineering and Information Technologies,  
Universității, no.1, Oradea, 410087,  
[lmatica@uoradea.ro](mailto:lmatica@uoradea.ro)

**Abstract** - The symmetric components values characterize three - phase electrical systems non-symmetry. The effects can be estimated by the symmetric components circulation. This paper contains a study that defines the equivalent electrical circuit for each symmetric component, in non-symmetrical situation.

**Keywords:** unbalanced consumer, source of negative symmetric components, source of zero symmetric components, unbalanced consumer.

## 1. INTRODUCTION

The real functioning situation of the distribution networks is non-symmetric and non-sinusoidal. Consequently in this work, some general problems will be presented that an analysis of the non-symmetric and sinusoidal situations encounters: the power circulation, the propagation of the non-symmetric situation. The three phase electric networks were conceived in order to function in balanced symmetrical situations. In these situations the component elements: transformers, lines, condenser batteries, reactance coils etc. present circuit parameters identical on each phase, and the voltage and current system in any section are symmetric. If one of the network's elements, or the consumers that are supplied by the network with electric energy, becomes unbalanced, the situation becomes non-symmetric, the voltage and current systems from different knots lose their symmetry.

The problems of the non-symmetric situation are: causes, effects, characteristic measures, the analysis of the non-symmetric situation, the propagation of the non-symmetric situation in network, the limitation of the situation, and the utility of the non-symmetric situation.

Some effects are: supplementary losses, the worsening of the power factor, parasite torque, and vibrations.

Characteristic measures are: non-symmetry coefficients, non-symmetry ratios, non-symmetry powers, power factor. The limitation of the non-symmetric situation are made by installations of symmetry or by the elaboration and follow-up of some normative to limit the non-symmetry degree. This paper had as goal that, from the problems diversity shown by the non-symmetrical situation analyses, to be analyzed mostly the problem that is referring of interaction between those situations and distributed or consumed electrical energy efficiency.

## 2. THE CIRCULATION OF POWER IN THREE - PHASE NETWORKS WITH UNBALANCED CONSUMER

The non-symmetric situation caused by some unbalanced consumers determines the increase of power losses. The increase of losses in non-symmetric situation can be based on supplementary power circulation of negative and zero sequence in the supplying network. The preservation theory of the complex, active and reactive powers allows the emphasis of these supplementary circulations.

Thus if we consider an electric subsystem formed of an ideal generator (G) that debits through an symmetrical electrical network (T), over two consumers, one balanced (E) and other unbalanced (N), fig. 1; the power debited by generator and received by network and absorbed by the two consumers expressed in symmetric components can be computed as follows:

$$\underline{S}_k = \underline{S}_k^+ + \underline{S}_k^- + \underline{S}_k^0 \quad k = G, T, E, N \quad (1)$$

The preservation theories of the complex apparent powers lead to the following preservation relations:

$$\underline{S}_G = \underline{S}_T + \underline{S}_E + \underline{S}_N \quad (2)$$

$$\underline{S}_{G\alpha} = \underline{S}_{T\alpha} + \underline{S}_{E\alpha} + \underline{S}_{N\alpha}$$

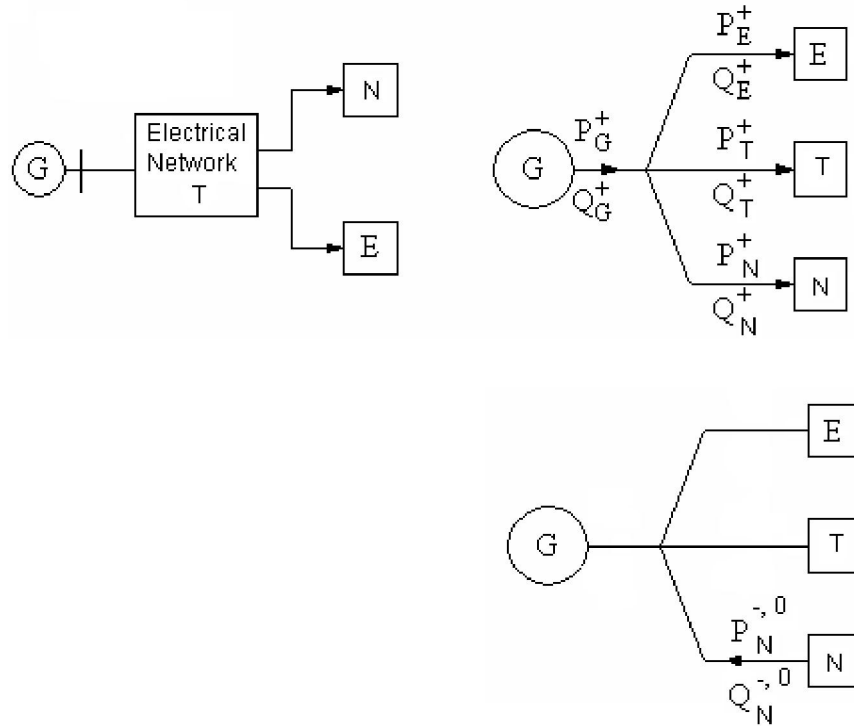

**Fig.1. The electrical power circulation in an electrical circuit with an unbalanced consumer N.**

Due to the fact that the generator's electromotive voltages form a symmetric three-phase system, of positive sequence, what results is that this one can debit powers only on positive sequence, so:

$$P_G = P_G^+ \quad P_G^- = 0 \quad P_G^0 = 0 \quad (3)$$

$$Q_G = Q_G^+ \quad Q_G^- = 0 \quad Q_G^0 = 0$$

The positive power components flow from the generator. The overall equations for the active and reactive powers become:

$$P_G^+ = P_T^+ + P_E^+ + P_N^+; \quad (4)$$

$$Q_G^+ = Q_T^+ + Q_E^+ + Q_N^+;$$

$$P_T^- + P_E^- + P_N^- = 0; \quad (5)$$

$$Q_T^- + Q_E^- + Q_N^- = 0;$$

$$P_T^0 + P_E^0 + P_N^0 = 0 \quad (6)$$

$$Q_T^0 + Q_E^0 + Q_N^0 = 0$$

The relations above show that the element which introduces the non-symmetry is the unbalanced consumer, fig.1. The positive power components flow from the generator. Consequently the electric generator debits powers to two consumers only on positive sequence, and the unbalanced consumer is the one that receives on positive sequence a higher power than it is necessary. A part from it is converted in powers of negative and zero sequence that it is injected again in

network, and at the balanced consumer, supplementing this way the power losses. In these circumstances, the networks of negative and zero sequence, corresponding to some three-phase networks that supply the unbalanced consumers, are no longer passive. It presents currents sources of negative and zero sequence, all these being exactly the unbalanced consumers. If the sources that supply the network are ideal, the voltages of negative and zero sequence at the unbalanced consumers' terminals correspond to voltage fallings on the sequence impedance and the network elements (line, transformers, coils, condensers). The source of the negative and zero power components is the unbalanced consumer.

### 3. THE CIRCULATION OF POWER IN THREE -PHASE NETWORKS WITH UNBALANCED CONSUMER.

In the condition presented above, the non-symmetrical situation must be analyzed in the plan of each symmetrical component. In the plan of positive sequence the power source is represented by the generators from the electro-energetic system. In the plan of negative or zero sequence components, the sources of currents debited in the electrical network are the unbalanced consumers. This is an analyze method. The situation is that the currents are non-symmetrical. Moreover, if the consumer is unbalanced, the corresponding network is decomposed in three sequence networks namely: positive, negative and zero.

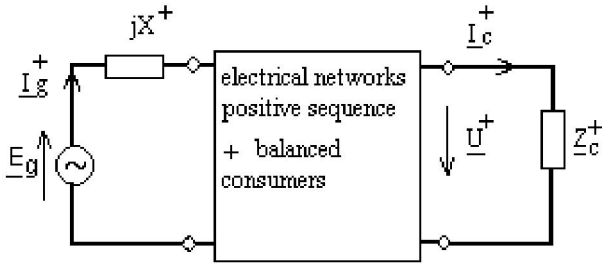

**Fig.2. Positive sequence structure of considered electrical network.**

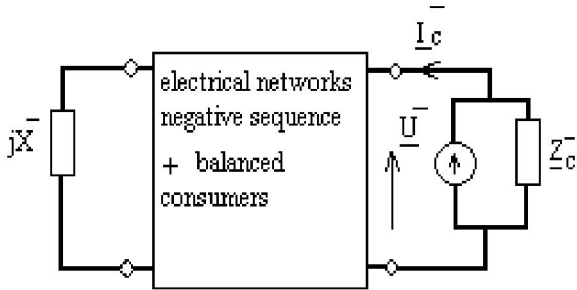

**Fig.3. Negative sequence structure of considered electrical network.**

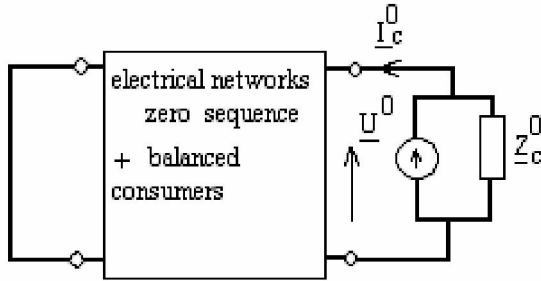

**Fig.4. Zero sequence structure of considered electrical network.**

The zero components do not flow to the generators because the generators have adapted protection.

#### 4. CONSIDERATIONS ABOUT NON-SYMMETRIC CONSUMER IN AN ELECTRICAL SYSTEM.

Let consider the optimum situation where the consumers are uniform distributed between the three phase:

$$\underline{Z}_R = \underline{Z}_S = \underline{Z}_T = \underline{Z}/3 \quad (7)$$

In those situations, the currents and the voltages, upon the three phases, form a symmetric system, the active power losses, in the electrical network, has the value [7]:

$$\Delta P_{sim} = 3 \cdot R \cdot I_{sim}^2 \quad (8)$$

, where  $I_{sim}$  is the symmetric electrical current through each phase.

In non-symmetric situations, the impedances are not equal:

$$\underline{Z}_R \neq \underline{Z}_S \neq \underline{Z}_T \neq \underline{Z}/3 \quad (9)$$

In those situations, the electrical active power losses, in low voltage electrical networks, can be computed by relationship:

$$\begin{aligned} \Delta P_{nesim} &= (I_R^2 + I_S^2 + I_T^2) \cdot R = \\ &= 3 \cdot (I_+^2 + I_-^2 + I_0^2) \cdot R \end{aligned} \quad (10)$$

In an electrical network with four conductors, the same relationship is where index  $n$  represents the fourth conductor:

$$\begin{aligned} \Delta P_{nesim} &= (I_R^2 + I_S^2 + I_T^2) \cdot R + I_n^2 \cdot R_n = \\ &= 3 \cdot (I_+^2 + I_-^2 + I_0^2) + 3 \cdot I_0^2 \cdot R_n = \\ &= 3 \cdot (I_+^2 + I_-^2) \cdot R + 3 \cdot I_0^2 \cdot R \cdot \left(1 + 3 \cdot \frac{R_n}{R}\right) \end{aligned} \quad (11)$$

From the previous relationships, it can be computed

the ratio  $\frac{\Delta P_{nesim}}{\Delta P_{sim}}$ .

The same ratio can be computed by another method, described as follow; so in non-symmetric situations, the electrical active power losses can be compute as:

$$\begin{aligned} \Delta P_{nesim} &= 3 \cdot R \cdot I_e^2 = \\ &= 3 \cdot R \cdot \sqrt{\frac{(I_R^2 + I_S^2 + I_T^2) + I_n^2 \cdot R_n/R}{3}} \end{aligned} \quad (12)$$

In symmetric situations, considering the equivalent electrical voltage, the electrical active power losses are:

$$\Delta P_{sim} = 3 \cdot R \cdot I_{sim}^2 \quad (13)$$

$$I_{sim} = \frac{3 \cdot U_e}{3 \cdot Z} = \frac{3 \cdot U_e}{U_R/I_R + U_S/I_S + U_T/I_T}$$

$$U_e = \sqrt{\frac{U_R^2 + U_S^2 + U_T^2}{3}}$$

The value that we defined as non-symmetry ratio, results from the relationships 12 and 13:

$$\frac{\Delta P_n}{\Delta P_{sim}} = \left( \frac{I_e}{I_{sim}} \right) = r_{nesim} \quad (14)$$

## 5. EXPERIMENTS, MODELING AND SIMULATION

It was considered a simple electrical network, 150 m long, fig.2:

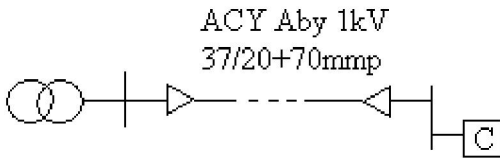

**Fig.5. Considered electrical network.**

For considered electrical network, we analyzed those situations:

- symmetrical situation, represented by index RS;
- first non-symmetrical situation, index RN1;
- second non-symmetrical situation, index RN2.

The results are exposed in Table I.

**Table 1. Experiment results for considered electrical network.**

No.	Formula; Units	RS	RN1	RN2
1	$U_e$ ; [V]	227	226.9	226.7
2	$I_e$ ; [A]	42.8	44.8	51.7
3	$I_{sim}$ ; [A]	42.8	42.9	43.2
4	$k_{ns}^-$	-	0.108	0.224
5	$k_{ns}^0$	-	0.081	0.170
6	$k_n$	-	0.190	0.394
7	$\Delta P$ ; [kW]	1692.6	1852.12	2494.4
8	$\Delta P_N / \Delta P_{sim}$ measured; [kW]	-	1.094	1.473
9	$\Delta P_N / \Delta P_{sim}$ rel.11; [kW]	-	1.057	1.251
10	$r_{nesim} = \Delta P_N / \Delta P_{sim}$ rel.14; [kW]	-	1.090	1.432

Far from give a complete solution at the characterizing problem of the unbalanced electrical energy consumers, the exposed analyze has the starting from the professor A. Țugulea theory, considering that in electrical networks with powerful sources, the source of sinusoidal non-symmetrical situation is the unbalanced consumers. Those criteria's introduction, together with the models make on base of the concept: source of perturbation non-symmetric situation is the unbalanced and non-linear consumer, assure a systemic approach of this problem. The main aspects analyze that involve the non-symmetrical situation is electrical current flows in systems that supply unbalanced consumers and use of the sequence components method.

Non-symmetrical situation propagation analyze in systems that supply unbalanced consumers or balanced and non-linear consumers distinguish the dependence between current and voltage non-symmetry coefficients, as well as voltage non-symmetry attenuation in network knots comparing with currents non-symmetry.

## 6. CONCLUSION

Referring of the power flow in electrical systems that supply unbalanced, it was notice that in non-symmetrical the unbalanced consumer absorb current, (active and reactive power), on positive sequence, a part is consumed while an other part is converted in negative and zero sequence to supplying electrical network.

This finding permit to establish a simple model for phase currents circulation from electrical network, that appeal of positive, negative and zero sequence components.

## REFERENCES

- [1] IEEE Working Group on Non-sinusoidal Situation, Practical definition for Power in Systems with Nonsinusoidal Waveforms and Unbalanced Loads: A Discussion. IEEE Transaction on Power Delivery, Vol.11, No.1, January 1996
- [2] Matica, L. M., Gavris, M., Three-phases systems analyze in non-symmetrical and non-sinusoidal situations. Edit.Univ. din Oradea, 2008; ISBN 978-973-759-534-8
- [3] Sharon,D., Power Factor Definition and Power Transfer Quality in Nonsinusoidal Situations. IEEE Transactions on instrumentation and measurement, no.3, iunie 1996, pg.728-733