

# THE USE OF PASSIVE CURRENT LIMITERS, A MODERN ALTERNATIVE AND EFFICIENT ALTERNATIVE TO REACTORS

DEZSI A.B.\*, ROSCA I.\*\* , VUC G.\*\*\*, DOZESCU S.I.\*

\*FFEE Electrica Supplying Transilvania Sud, Brasov,

\*\*FDEE Electrica Distribution Transilvania Sud, Braşov

\*\*\*Polytechnic University, Timisoara

[alexandru.dezsi@electricats.ro](mailto:alexandru.dezsi@electricats.ro)

**Abstract - The paper describes the operating mode of passive current limiters and reactors, the current and voltage variation in case of short circuits accompanied by big fault currents, as well as the phenomena that come along with these events. There are also efficiency calculations in case of using both types of equipment and comparisons of the advantages of using each of them.**

**Keywords:** passive current limiter, reactor, modelling, reliability protection system, electrical network.

## 1. GENERAL CONSIDERATIONS

In electronic circuits where the short circuit currents can have very high values, we must take measures to limit them, in order to ease the current path load and to be able to choose the breakers capable to interrupt the short circuit currents with reasonable values.

For this, serial in the respective circuits, are introduced these current limiters (passive current limiters (LC) [1, 4] or reactors (BR)).

Taking into consideration the serial connection of these elements, therefore they are passed by the load current, this elements have to present losses as small as possible during normal operating conditions, in order not to have negative after-effects from the economic point of view on the whole electric installation assembly.

Now days are largely used, as current limiters, reactors and in our country are used exclusively.

As a modern alternative, considering the advantages that they are presenting, in the developed countries, the current limiters are more and more used.

A slightly less economic variant, but with technical advantages, is the mixed use (in the same circuit are used both reactors and passive current limiters).

## 2. SHORT PRESENTATION OF THE PASSIVE CURRENT LIMITERS

The passive current limiter is electric equipment used especially on medium voltage, but in some application also on the low voltage. Is modern

equipment, used more and more in the electric installation from the developed countries and certainly, in the near future, shall enter in the electric installations from our country.

Using the passive current limiter the following problems are solved:

- The fault current value is limited;
- The interruption time of the fault current is shortened, being interrupted in maximum 1 ms (in the first semi-period), which with classic electromecanic systems with energy stockage (with spring, oleo pneumatic, etc.), these short times cannot be obtained;
- They can interrupt high current values, which only the systems based on reactors can accomplish.

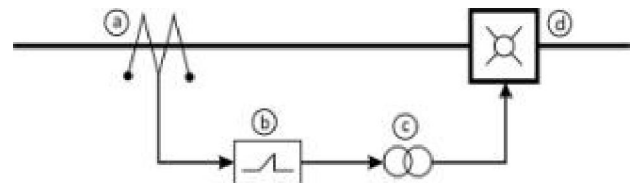

**Fig. 1. Principle scheme for the current limiter usage**

As seen in Fig.1., a system that uses passive current limiter, is made up of the following elements [1]:

- The current transformer that evidenciate the short circuit currents;
- The measurement and command equipment, composed of a secondary circuits cabinet and that includes: a continuous voltage source; an own circuit breaker that allow the connection and disconnection of the equipment; a monitoring module for the equipment functions; the current measurement unit for each phase, that processes the information received from the current transformers; one command unit for each phase that assures the limiter command and the energy necessary for the limiter to work; a signaling unit and an unit for protection against exterior influences that can cause faulty equipment functioning and, naturally, the connection elements necessary between the measurement and command equipment units;
- The impulse converters, that are converting the commands received from the measurement and command equipment into limiter triggering impulses;
- So called limiter.

The composing elements of the limiter are presented in Fig.2. and Fig.3.

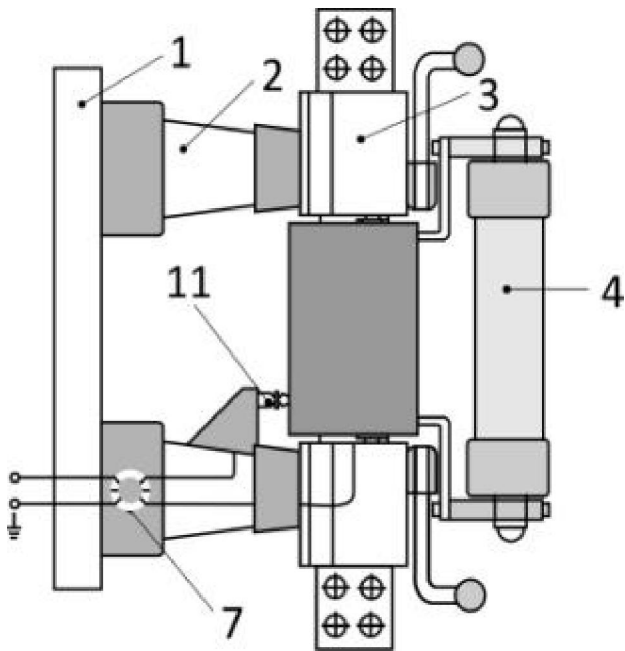

Fig. 2. Main composing elements of the limiter

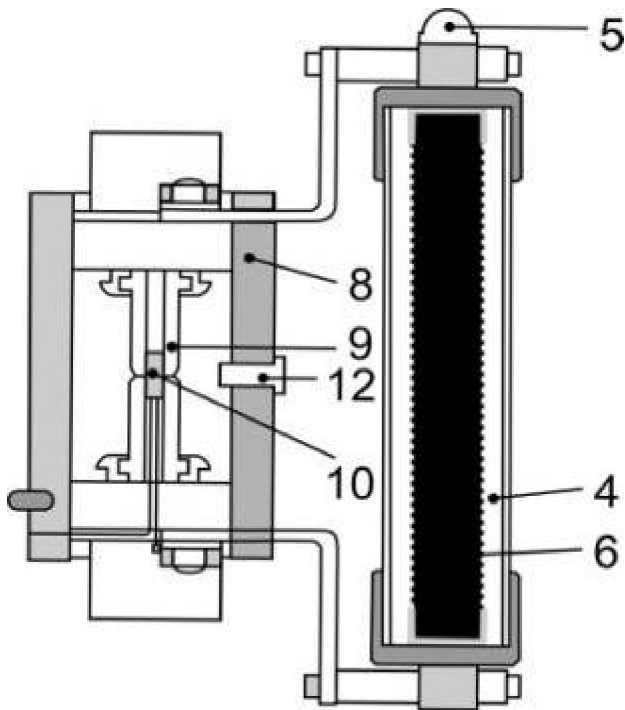

Fig. 3. Section through ultra-rapid breaker and fuse

The limiter consist of, as a rule, an ultra-rapid breaker, dimensioned for high nominal currents, but having a small break power, mounted parallel with a high breaking power fuse.

The limiter has a support (1), with whom it is fixed directly inside a cell or on the medium voltage cell carriage, support that is connected to mass through the insulator (2), the main elements are fixed on the support. The fixing device (3) can be with broach for rated currents smaller than 2000 A, or fixed with screws, for current bigger than 2000 A. Parallel with ultra-rapid breaker is mounted a high breaking power fuse (4),

equipped with a functioning indicator (5), for the case of fusible elements (6) is burned.

The impulse transformer (7) is mounted inside the body of one of the insulators, through him being made the connection between the measuring and command equipment and the ultra-rapid breaker.

The ultra-rapid breaker is made of an insulated tube (8), of burly construction, that have inside an interruptible current path (9) and a kamikaze pill (10), which is self-destroying during functioning, breaking the current path.

The impulse that determines the self-destruction of the pill is sent from the impulse transformer to kamikaze pill through the telescopic contact (11). The ultra-rapid breaker functioning is visualized on the indicator (12) mounted on his body.

Further is described the passive current limiter functioning [1].

The moment that the current path, on which we want to limit the current and on which is mounted the limiter, a fault current appears, it is detected by the current transformer, which through the secondary circuits is sending the information to the measure and command equipment. Here the information is processed. In measured the fault current value, is compared cu the minimum value on which the limiter must work (is measured both the instantaneous value and its derivative value with respect to time and only if the both adjusted values are surpassed, the working conditions are fulfilled).

It is established which are the phases affected by the fault current, it is memorized and the solution is displayed, then a signal is transmitted to the impulse transformer, which in its turn is sending an impulse to the kamikaze pill.

In order to produce a short opening time, in the pill is stored an energy sufficient that the moment when it receives the impulse, this special pill, through its self-destruction, to be able to interrupt the current path from the ultra-rapid breaker.

When this current path, on which at normal transformation the current is circulating, is interrupted, the current will continue to circulate through the fuse mounted in parallel, where in approx. 0,5 ms is limited and then, finally, on the first passing through zero, is interrupted.

The three limiters, mounted on the three phases, are working independently working, but linked to the same measure and command equipment.

In fig. 4 is represented a simple feeding scheme in which the passive current limiter is serial with the distribution transformer.

In case of a fault K on line  $L_1$  fed from the transformer TE, the current both on the faulty line and through the limiter has the value  $I_{SC}$ . In Fig.5. is shown the current evolution in case of limiters absence ( $I_{SCa}$ ) and in limiters presence ( $I_{SCb}$ ). It can be observed the great difference between the currents in the two cases above (with and without limiter).

If the passive current limiter is used, the maximum current value is obtained at  $t_1$  moment (maximum 0,5 ms), when the base current path is interrupted by the ultra-rapid breaker, following that to his complete

interruption, to circulate through the fuse (maximum 1 ms) till  $t_2$  moment.

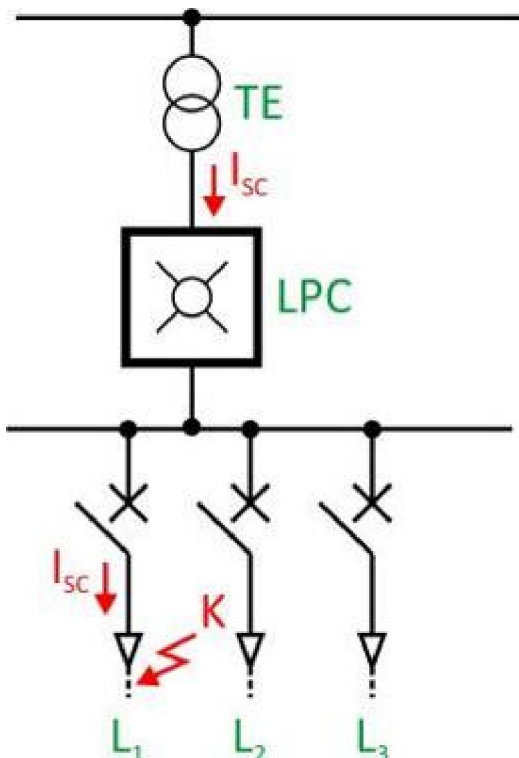

Fig. 4. Distribution scheme with one transformer

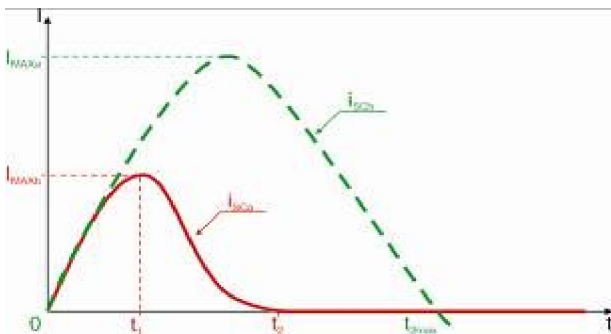

Fig. 5. Fault current evolution in case of the Fig. 4. Scheme

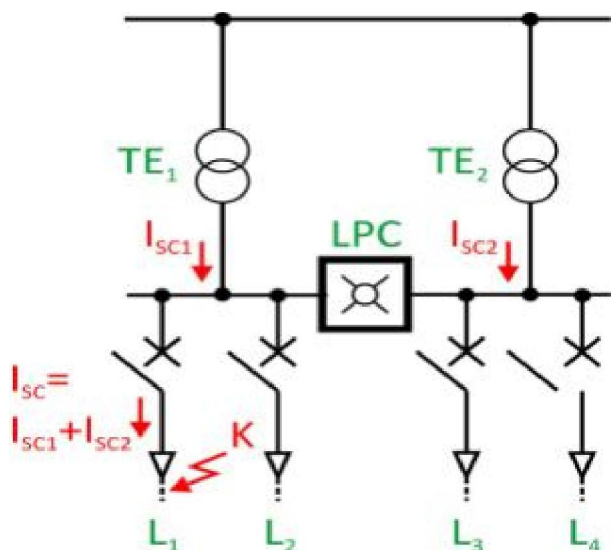

Fig. 6. Distribution scheme with two transformers and one limiter

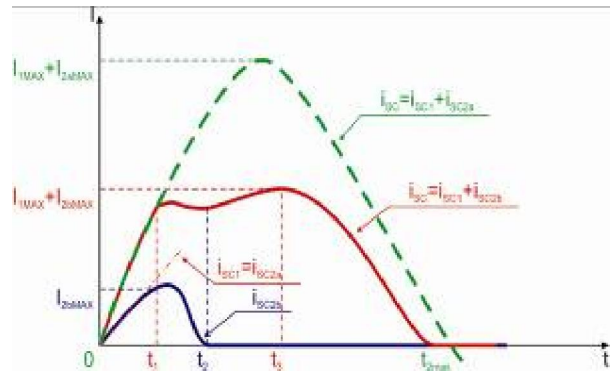

Fig. 7. Fault current evolution in case of the Fig. 6. Scheme

For a feeding scheme with two identical transformers, it exists the possibility to mount one limiter serial to each transformer, when the problems happens like in case of one transformer (when the longitudinal coupling is open), or to place the passive current limiters like in Fig.6., and the fault current evolution, with and without limiter, is presented in Fig.7.

In this situation is observed that, in case of passive current limiter usage, the maximum value of the fault current is half of its value compared to the situation when the passive current limiter is not used.

### 3. SHORT PRESENTATION OF THE REACTOR

The reactors are widely used, on medium voltage, in the stations where the short circuit power is high [2, 3, and 5].

By using the reactors the following problems are solved:

- The fault currents values are limited;
- Contribute to the bus-bar voltage maintaining in case of failure, to an acceptable level, which will provide the functioning without interruption for the unaffected consumers.

The main parameters of a reactor are:

- $U_n$  – rated voltage;
- $I_n$  – rated current;
- $X_n$  – rated reactance.

Where:

$$X_n = \omega \cdot L \quad (1)$$

$$X_n \% = \frac{X_n \cdot \sqrt{3} \cdot I_n}{U_n} \cdot 100 \quad (2)$$

There are several modes of placement the reactor in the primary medium voltage circuits, in whom we want to limit the short circuit currents, them being presented in Fig.8.

In Fig.8.a. the reactor is placed between the power transformer and the bus-bars. This mode of placement has the advantage of limiting the short circuit currents in the whole downstream installation ( $K_1, K_2$ ), but has the disadvantage that the reactor must be over dimensioned.

In Fig.8.b. the reactor is placed on the exit power main, having the advantage of limiting the short circuit currents only on the line (K) on which is mounted, but its dimensioning is made considering only the current on this specific line.

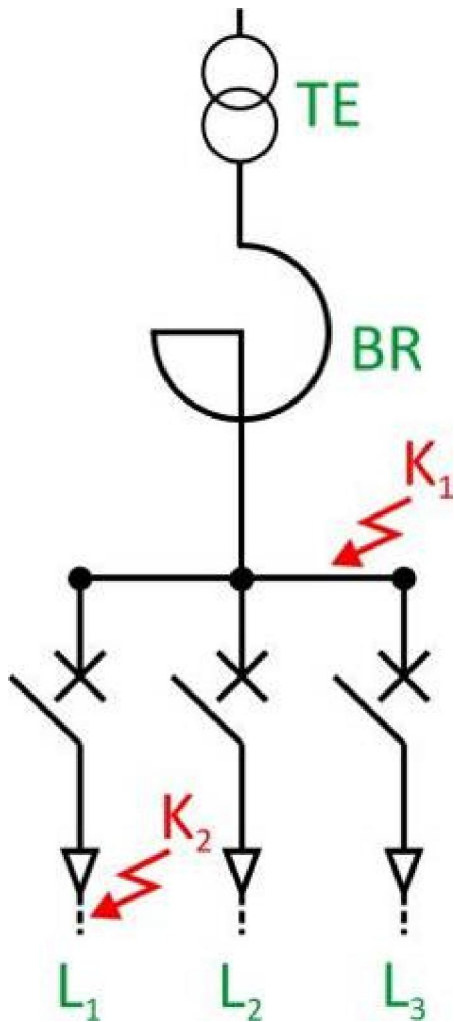

Fig. 8.a. BR placement in the transformer circuit

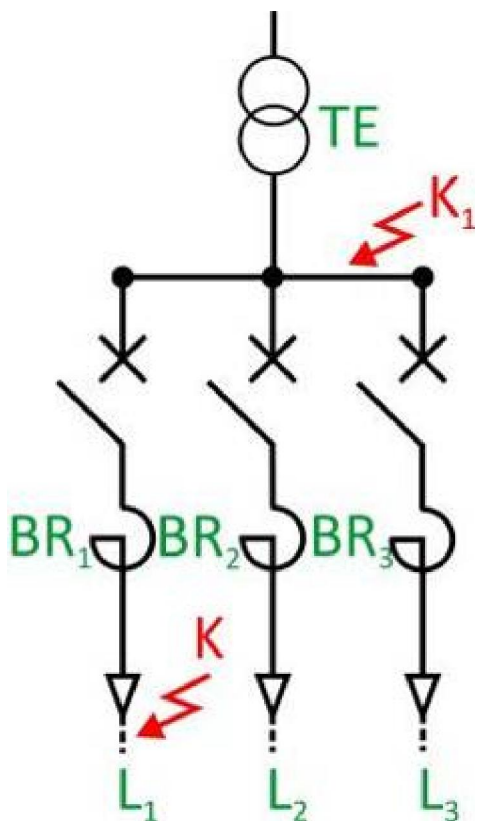

Fig. 8.b. BR placement in the exit power main circuit

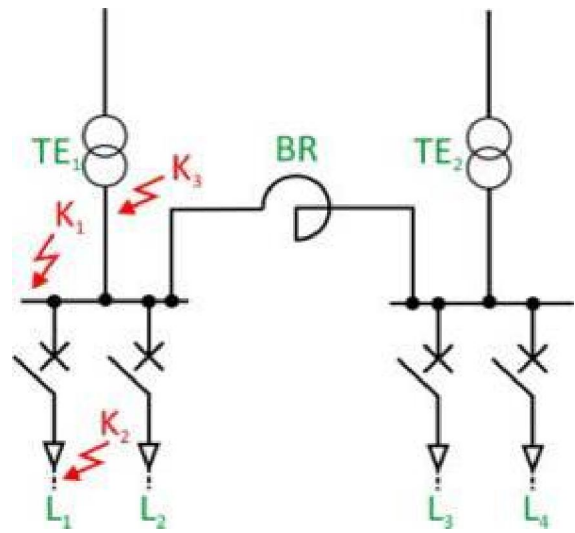

Fig. 8.c. BR placement in the bus-bars section

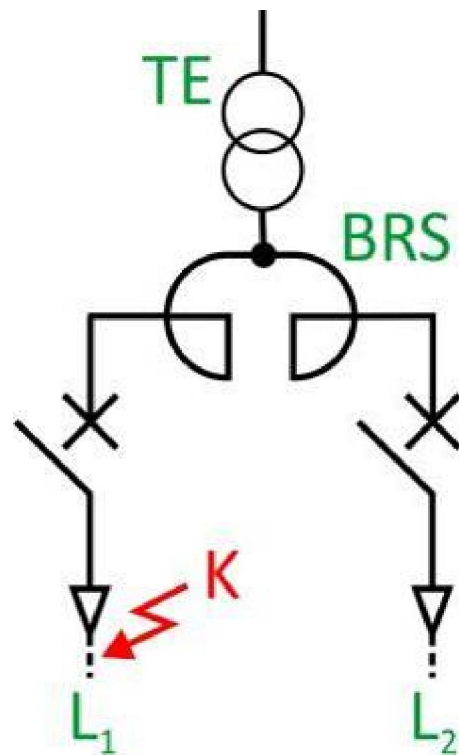

Fig. 8.d. Sectioned BR

In Fig.8.c. the reactor is placed on the longitudinal coupling. This placement mode, where two or more power transformers exist, has economic advantages and also contributes to the short circuit currents limiting (other section transformers contribution), both for line short circuit currents ( $K_2$ ), sections short circuit currents ( $K_1$ ) and feeding line short circuit currents ( $K_3$ ), but it cannot limit the contribution of the short circuit currents on the feeding line corresponding to the faulty section.

In Fig.8.d. is presented the placement of a sectioned reactor (twin), that serves two lines, limiting the short circuit current on each of the lines ( $K$ ).

Certainly are existing more modes of placement or combined modes.

For choosing (dimensioning) the reactor we must consider that, during normal working regime, its reactance must be at most 6÷8%, excepting the case when is placed on the longitudinal coupling, when it can

be of maximum 10÷12% due to the fact that for a good equillibration of the consumption on the sections, on normal working regime, the current in the reactor is small [6, 7].

In Fig.9. are presented for normal operating conditions, with reactor, the voltage drops and phases diagram.

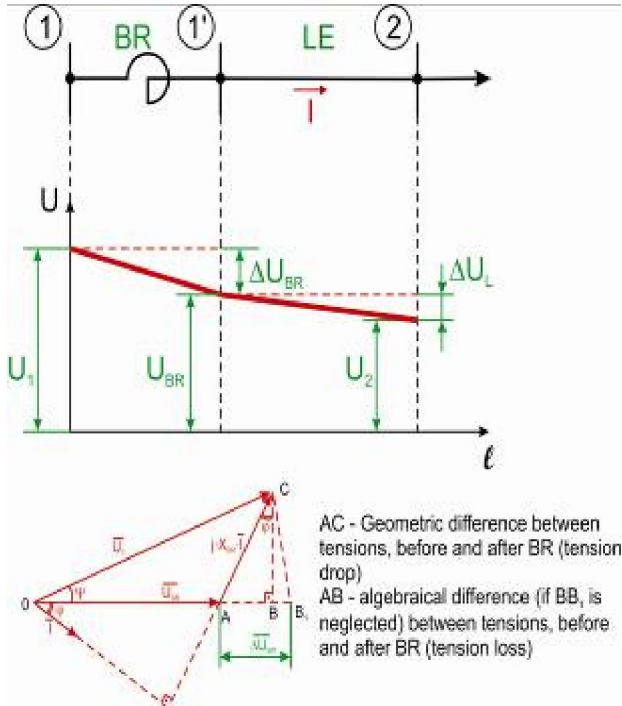

Fig. 9. Reactor normal operating conditions

The voltage drops during short circuit regime are presented in Fig.10. [9].

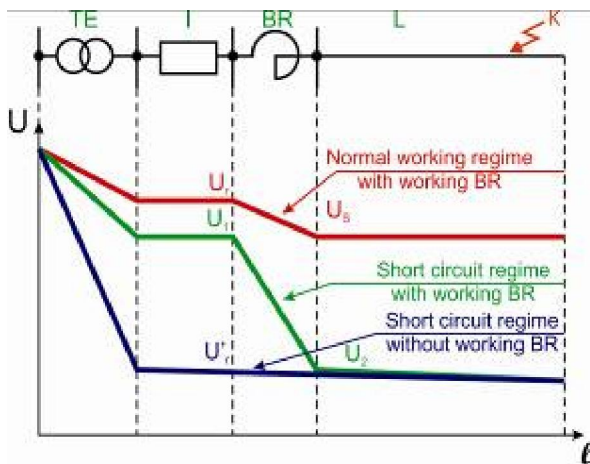

Fig. 10. Voltage drops during short circuit regime

In Fig.10. are observed the voltage drops evolution between the source and the fault place, compared for normal working regime and short circuit regime, in both cases of reactor presence and absence. The notations in the diagram are representing:

- $U_5$  – working voltage;
- $U_r$  – bus-bars residual voltage with BR;
- $U_r'$  – bus-bars residual voltage without BR ;
- $U_1, U_2$  – Exit and entrance binding-post voltage for BR.

The reactor dimensioning [10] must be made thus the voltage losses during normal working regime are respecting the following limits:

$$\Delta U_{BR} \% = X_{nBR} \cdot \frac{\sqrt{3} \cdot I_{max} \cdot \sin \varphi}{U_n} \cdot 100 \leq (1,5 \div 2)\% \quad (3)$$

and the bottoming voltage during short circuit regime are framed in the following limits:

$$\Delta U_r \% = X_{nBR} \cdot \frac{\sqrt{3} \cdot I_r}{U_n} \cdot 100 \geq (65 \div 70)\% \quad (4)$$

where:

- $I_{max}$  – maximum current during normal working regime;
- $I_r$  – breaking current of the circuit breaker.

#### 4. COMPARISONS BETWEEN PASSIV CURRENT LIMITER AND REACTOR. ADVANTAGES AND DISADVANTAGES

In medium voltage electric installation both variants are used in order to limit the short circuit currents, with the advantages and disadvantages that they are presenting.

Further are pointed out the main technical and economic aspects regarding the passive current limiters usage, respectively the reactors.

##### 4.1. Short circuit currents limiting time

If the short circuit currents have great values, over the working limit of the passive current limiters, they are quickly interrupted, in the first semi-period, therefore:

$$t_{sc} \leq 1ms \quad (5)$$

While when using reactors, the short circuit currents interruption is made through classic methods (protective relays and circuit breakers), case where:

$$t_{sc} \in (0,5 \div 3)ms \quad (6)$$

depending on the spot where the current is limited.

A short interruption time has the advantage that the installation elements traversed by the fault current are less stressed.

If the short circuit current have small values, below the working limit of the passive current limiters, the interruption time is the same for both variants (6), being interrupted through classic methods. In this case, by using reactor, this currents are reduced to a certain extent.

##### 4.2. Additional serial impedances

The use of reactors means to seriatim on the electric circuits of additional impedances, with negative economic effects. The electric installations losses are growing (the reactors losses) that meaning additional exploitation costs.

Following the analysis made in st. 110/6 kV Astra from Brasov, was noticed that these losses have a weight, as part of the total losses in the station, the following approximate value:

$$p_{BR} \% = 0,08 \cdot p_t \% \quad (7)$$

which is not a neglectable value.

### 4.3. Voltage level

During normal working regime, the use of passive current limiters is not causing voltage drops, while using reactors causes voltage drops downstream from the mounting point. Even more, the voltage drops are depending on the charge variations, that burdens more the control on the voltage level. Concomitantly, the voltage variations can have negative effects for the consumers, specially the case of big motors starting.

Therefore, when choosing the reactors, the voltage drop variation limits, during normal working regime, must be as small as possible.

During short circuit regime, the passive current limiters have a remarkable advantage, meaning that the voltage in the unaffected part of the electric installations is dropping only for a fraction of a millisecond, so that even the most sensitive consumers (computers for example) are not affected by the voltage drops. In case of using reactors, the short circuit current liquidation process being slower, the voltage drop during transition process is experienced by all consumers.

### 4.4. Short circuit currents effects on the limiting equipment.

In this case, the advantages are on the reactors side. The short circuit current are producing in the reactors, due to Joule-Lenz effect, heating, which in time, when functioning, can lead to the insulation ageing, but for passive current limiters are causing the kamikaze pill self destruction, which can lead to the shut-down of the ultra rapid circuit breaker shut-down and later of the high breaking power fuse.

The ultra rapid circuit breaker and the high breaking power fuse, after one action, must be changed (on the phases affected by the short circuit current), or they can be reconditioned in specialized shops, with relatively small costs and then it can be reused.

### 4.5. Investment expenses.

If we compare the investment expenses regarding the mounting of a passive current limiter and of a reactor, the advantages are on passive current limiter side.

Beside the expenses regarding the acquisition of the respective equipment and mounting costs, we must consider their mounting place. If the passive current limiters are mounted inside the medium voltage cells, the reactors need large spaces and separate wall-up constructions, in order to be mounted and to ensure necessary cooling space, that highly increasing the investment cost.

Following the laborious calculations made, was found that it exist a report between the investment expenses for passive current limiters ( $C_{LPC}$ ) and investment expenses for reactors ( $C_{BR}$ ):

$$C_{BR} / C_{LPC} \cong 2,1 \quad (8)$$

## 5. USE OF THE PASSIVE CURRENT LIMITERS AND REACTORS

Lately, in the developed countries, are often used passive current limiters and reactors, thus joining the

technical advantages of the two types of current limiters, of course to investment costs detriment, which in this case are bigger [1, 8].

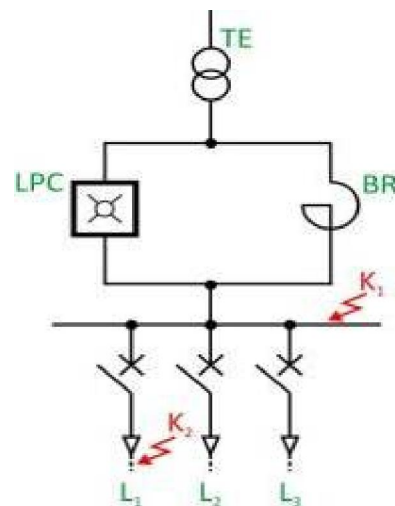

Fig. 11.a. Parallel mounting of the LPC and BR in the main feeding circuit

This association between passive current limiter and reactor has numerous advantages.

During normal working regime, the reactor is bypassed, so, virtually [8], is not traversed by the load current, the power losses are void, that eliminating the main deficiency of the sole reactor use. Also during normal working regime, also because the reactor is bypassed, the voltage drop on the reactor is void, that eliminating the negative influences on the consumers, due to voltage drops.

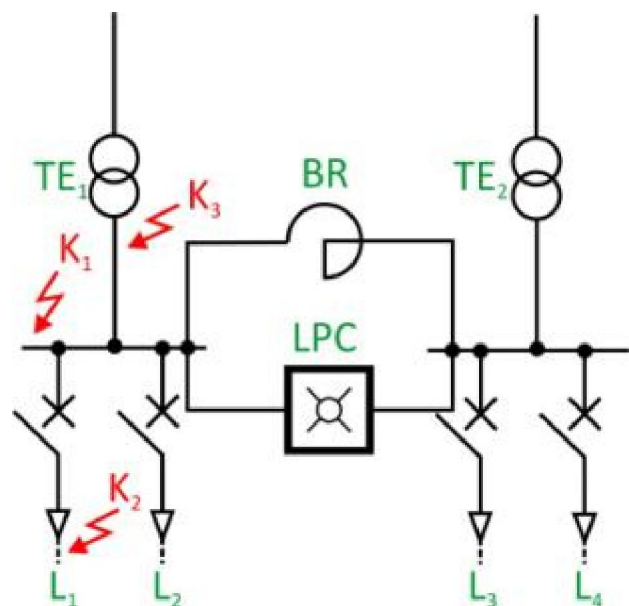

Fig. 11.b. Parallel mounting of the LPC and BR on the longitudinal coupling

In Fig.11.a. and Fig.11.b. are two examples where the passive current limiter is mounted parallel to the reactor, the first case in the main feeding circuit, the second case on the longitudinal coupling.

On short circuit regime, when the current does not exceed the working value of the passive current limiter, the fault current is limited by the reactor to permissible

values in order to ease the functioning of the breaker that breaks the fault current.

During short circuit regime, when the current value exceeds the working limit of the passive current limiter, the fault current is rapidly limited, avoiding its shock value. Then, the reactor enters in service and it will reduce also the value of the remaining current, easing the working regime of the circuit breaker that interrupts the fault current.

## 6. CONCLUSIONS

Although nowadays the use of passive current limiters is not sufficiently spread, considering their advantages compared to the reactors, their use in the near future is imminent, even more in our country where they are not used now.

The technical and economic advantages, both in investment and in exploitation phases, are imposing the passive current limiters as a modern alternative, to reactors disadvantage.

Where the investment expenses are not a problem, the association of the passive current limiters with the reactors, present both type of limiters advantages. Even more, in our stations, where the reactors are existing already, in case of modernisation actions, we can parallel mount, with the reactors, passive current limiters.

## REFERENCES

- [1]. \*\*\* - Is limiter, ABB Calor Emag Schltanlangen AG, Mannheim, 2000
- [2]. Anoaica, Nicolae; Anoaica, Paul-Gabriel. – Bobine de reactanța fără miez ferromagnetic, Universitatea din Craiova, 2009
- [3]. Bălă, Constantin; ș.a. – Bobine de reactanță pentru sisteme energetic, Ed.Tehnică, București, 1982
- [4]. Dezi, Alexandru; Vuc, Gheorghe – Limitatoare passive de current. Aspecte ale utilizării acestora la diferite nivele de tensiune, Conferința Internațională de Energetică, Oradea, 2002
- [5]. Gheorghiu, Nicolae ; ș.a. – Echipamente electrice, Ed. Didactică și Pedagogică, București, 1981
- [6]. Hercovici, Bercu; ș.a.– Aparat electrice de înaltă tensiune, Ed.Tehnică, București, 1981
- [7]. Lezeu, Aurel; Coroiu, Nicolae. –Echipamente și aparate electrice, Universitatea din Oradea, 1998
- [8]. Munteanu, Florin; ș.a. – Centrale electrice – partea electric. Analiza fenomenului de scurtcircuit, vol.1, Ed.Setis, Iași, 2005
- [9]. Vasilievici, Alexandru ; Andea, Petre – Aparat și echipamente electrice, Ed. Orizonturi Universitare, Timișoara, 2000
- [10]. Vasilievici, Alexandru – Aparat și echipamente electrice, vol.2, Ed. Mircea Sîrbu & Co, Sibiu, 1996